



Inspur Server User Manual
NF5266M5

© Copyright Inspur 2018. All rights reserved.

No part of this document may be reproduced or transmitted in any form or by any means without prior written consent of Inspur.

The information in this manual is subject to change without notice.

Inspur is the registered trademark of Inspur. All the other trademarks or registered trademarks mentioned in this manual are the property of their respective holders.

Edition: 1.8

May, 2021

Editon Statement:Add numbers and names for some figures and tables.

Abstract

This manual contains technical information such as specifications, hardware operations, software configuration, fault diagnosis, etc., that are relevant to the maintenance and operation of this server.

It is recommended that server installation, configuration and maintenance is performed by experienced technicians only.

Target Audience

This manual is intended for:

- Technical support engineers
- Product maintenance engineers
- Technicians

Warnings:

This manual introduces the NF5266M5 server's technical features, system installation and setup, which will help the user to understand how best to utilize the server and all its functions.

1. For your safety, please do not disassemble the server's components arbitrarily. Please do not extend configuration or connect other peripheral devices arbitrarily. If needed, please contact Inspur for our support and guidance.
2. Before disassembling the server's components, please be sure to disconnect all the power cords connected to the server.
3. BIOS and BMC setup is a significant factor in correctly configuring your server. If there are no special requirements, it is suggested to use the Default Values and not alter the parameter settings arbitrarily. After the first login, please change the BMC user password in time.
4. Please install the product-compatible operating system and use the driver provided by Inspur. If you use an incompatible operating system or non-Inspur driver, it may cause compatibility issues and affect the normal use of the product, Inspur will not assume any responsibility or liability.

Inspur is not responsible for any damages, including loss of profits, loss of information, interruption of business, personal injury, and/or any damage or consequential damage without limitation, incurred before, during, or after the use of our products.

Contents

1 Safety Instructions	1
2 Product Specifications	5
2.1 Introduction.....	5
2.2 Features and Specifications	5
2.3 Power Efficiency	8
3 Component Identification	10
3.1 Front and Rear Panel Components.....	10
3.2 Left and Right Ear Components	12
3.3 Motherboard Components.....	13
3.4 Motherboard Jumper Introduction	14
4 Operations.....	15
4.1 Power up the Server	15
4.2 Power down the Server	15
4.3 Extend the Server from the Rack.....	15
5 Setup	17
5.1 Optimum Environment.....	17
5.2 Rack Warnings	19
5.3 Identifying the Contents of the Server Shipping Carton.....	20
5.4 Installing Hardware Options	20
5.5 Installing the Server into the Rack.....	21
5.6 Installing the Operating System.....	21
6 Hardware Options Installation.....	22
6.1 Processor Option	22
6.2 Memory Option	25
6.3 Hot-plug HDD Option	26
6.4 Redundant Hot-plug Power Supply Option	28
6.5 Air Baffle Option	29

6.6 TPM Option	30
6.7 M.2 SSD Option	30
6.8 OCP/PHY Card Option	31
7 Cabling	32
8 BIOS Setup	33
8.1 Common Operations	33
8.2 BIOS Parameter Description	50
8.3 Firmware Update	91
9 BMC Settings	96
9.1 Introduction	96
9.2 Functional Modules	97
9.3 Web Interface Introduction	98
9.4 Storage	104
9.5 Remote Control	104
9.6 Power and Fan	106
9.7 BMC Settings	107
9.8 Logs	111
9.9 Fault Diagnosis	113
9.10 Administration	114
9.11 Command Line Function Introduction	118
9.12 Time Zone Table	124
10 Common Faults, Diagnosis and Troubleshooting	126
10.1 Hardware Problems	126
10.2 Software Problems	129
11 Battery Replacement	131
12 Regulatory Compliance Notices	132
12.1 Regulatory Compliance Identification Numbers	132
12.2 Federal Communications Commission Notice	132

12.3 Cables	133
12.4 European Union Regulatory Notice	133
12.5 Disposal of Waste Equipment by Users in the European Union	133
12.6 Korean Notice	134
12.7 Chinese Notice	134
12.8 Battery Replacement Notice	134
12.9 Battery Caution	135
12.10 Restricted Access Area	136
13 Electrostatic Discharge	137
13.1 Preventing Electrostatic Discharge	137
13.2 Grounding Methods to Prevent Electrostatic Discharge	137
14 Warranty.....	138
14.1 Introduction.....	138
14.2 Warranty Service	138
14.3 Warranty Exclusions	139
15 Appendix	140
15.1 Drive Neodymium Content Reference.....	140

1 Safety Instructions



WARNING: Please be advised to follow the instructions below for safety. Failure to do so could result in potential dangers that may cause property loss, personal injury or death.

1. The power supplies in the system may produce high voltages and energy hazards that may cause personal injury. For your safety, please do not attempt to remove the cover of the system to remove or replace any component without assistance provided by Inspur. Only service technicians trained by Inspur are authorized to remove the cover of the host, and to remove and replace internal components.
2. Please connect the equipment to the appropriate power supply. Use only power supplies with the correct voltage and electrical specifications according to the label. To protect your equipment from damages caused by a momentary spike or plunge of the voltage, please use relevant voltage stabilizing equipment, or uninterruptible power supplies.
3. If you must use an extension cable, please use a three-core cable with properly grounded plugs. Observe extension cable ratings. Ensure that the total rating of all equipment plugged into the extension cable does not exceed 80 percent of the ratings limit for the extension cable.
4. Please be sure to use the power supply components that come with the server, such as power cables, power socket (if provided with the server) etc. For your safety, please do not replace power cables or plugs randomly.
5. To prevent electric shock dangers caused by leakage in the system, please make sure that the power cables of the system and peripheral equipment are correctly connected to the earthed/grounded power socket. Please connect the three-core power cable plug to the three-core AC power socket that is well earthed and easy to access. Be sure to use earthing/grounding pin of power cables and do not use the patch plug or the earthing/grounding pin unplugged with cables. In the case that the earthing/grounding conductors are not installed and it is uncertain whether there are appropriate earthing/grounding protections, please do not use or attempt to operate the equipment. Contact and consult an electrician.
6. Please do not push any objects into the openings of the system. Doing so may cause fire or electric shock.
7. Please place the system far away from the cooling plate and heat sources, and be sure

- not to block the air vents.
8. Please be sure not to scatter food or liquid in the system or on other components, and do not use the product in humid or dusty environments.
 9. Using an incompatible battery may cause explosion. When battery replacement is required, please consult the manufacturer first, and choose batteries of the same or equivalent type. Do not disassemble, crush, puncture the batteries or make the external connection point short circuit, and do not expose them in the environment over 60°C. Never throw batteries into fire or water. Please do not attempt to open or repair the batteries. Dispose of used batteries according to instructions. For battery recycling, please contact the local waste recycling center.
 10. Before installing equipment into the rack, please install all front and side stabilizers on the independent rack first. Please install the front stabilizers first, if connecting with other racks. Please install stabilizers before installing equipment into the rack. Failure to install the corresponding stabilizers before installing equipment into the rack may cause the cabinet to tip over, possibly resulting in severe injury. After installing the equipment and other components into the rack, only one component can be pulled out from the rack through its sliding part at one time. Pulling out several components at the same time may cause the rack to turn over, resulting in serious personal injury.
 11. A minimum of two people are required to safely move a rack. The racks are extremely awkward and heavy, moving them without adequate, trained personnel could result in severe injury or death.
 12. It is prohibited to directly short-circuit the copper busbar. Please do not touch the copper busbar when the rack is powered on.
 13. This is Class A product, and may cause radio interference. In such case, users may need to take necessary measures to mitigate the interference.
 14. The equipment is intended for installation in a Restricted Access Location.



Note: The following considerations may help avoid the occurrence of problems that could damage the components or cause data loss, etc.

1. In the event of the following, please unplug the power cable plug from the power socket and contact Inspur's customer service department:
 - 1) The power cables, extension cables or power plugs are damaged.

- 2) The products get wet.
 - 3) The products have fallen or have been damaged.
 - 4) Other objects have fallen into the products.
 - 5) The products do not or are unable to function normally even when attempting to operate according to the instructions.
2. If the system becomes wet or damp, please follow these steps:
 - 1) Power off the equipment, disconnect them with the power socket, wait for 10 to 20 seconds, and then open the host cover.
 - 2) Move the equipment to a well-ventilated place to dry the system at least for 24 hours and make sure that the system is fully dried.
 - 3) Close the host cover, reconnect the system to the power socket, and then power on.
 - 4) In case of operation failure or other abnormal situations, please contact Inspur and get technical support.
 3. Pay attention to the position of system cables and power cables-avoid placing wires in high foot traffic locations. Please do not place objects on the cables.
 4. Before removing the host cover, and/or touching the internal components, please allow for the equipment to cool first. To avoid damaging the motherboard, please power off the system and wait for five seconds, and then remove the components from the motherboard and/or disconnect the peripheral device from the system. Please remember that only service technicians trained by Inspur are authorized to remove the cover of the host, and to remove and replace internal components.
 5. If there is modem, telecom or LAN options installed in the equipment, please pay attention to the followings:
 - 1) In the case of thunder and lightning, please do not connect or use the modem.
 - 2) Never connect or use the modem in a damp environment.
 - 3) Never insert the modem or telephone cables into the socket of network interface controller (NIC).
 - 4) Before unpacking the product package, installing internal components, touching uninsulated cables or jacks of the modem, please disconnect the modem cables.
 6. In order to prevent electrostatic discharge from damaging the electronic components in the equipment, please pay attention to the followings:
 - 1) Please remove any static electricity on your body before dismounting or touching any electronic component in the equipment, to prevent the static electricity from

conducting itself to the sensitive components. You may remove the static electricity on the body by touching the metal earthing objects (such as the unpainted metal surface on the rack).

- 2) Please do not take electrostatic sensitive components that are not ready to be installed for application out of the antistatic package materials.
- 3) While working, please touch the earthing conductor or the unpainted metal surface on the cabinet regularly to remove any static electricity from the body that may damage the internal components.
7. Upon receiving the proper authorization from Inspur and dismantling the internal components, please pay attention to the followings:
 - 1) Switch the system power supply off and disconnect the cables, including all connections of the system. When disconnecting the cables, please hold the connector of the cables and slowly pull the plugs out. Never pull on the cables.
 - 2) The products need to completely cool down before dismantling the host cover or touching the internal components.
 - 3) During the dismantling process, avoid making large movement ranges to prevent damage to the components or scratching arms.
 - 4) Handle components and plug-in cards with care. Please do not touch the components or connection points on the plug-in cards. When handling the plug-in cards or components, firmly grab the edges of the plug-in cards and components, and/or their metal fixed supports.
8. During the process of rack installation and application, please pay attention to the followings:
 - 1) After the rack installation is finished, please ensure that the stabilizers have been fixed to the rack and supported to ground, and the weight of the rack is firm on ground.
 - 2) Always load from the bottom up, and load the heaviest items first.
 - 3) When pulling out the components from the rack, apply slight force to keep the rack balanced.
 - 4) When pressing down the release latch and the rail of components is sliding, please be careful; as the sliding may hurt your fingers.
 - 5) Do not overload the AC power supply branch circuits in the rack. The total load of the rack should not exceed 80% of the ratings of the branch circuits.
 - 6) Ensure that components in the rack have good ventilation conditions.
 - 7) When repairing components in the rack, never step on any other components.

2 Product Specifications

2.1 Introduction

Inspur server NF5266M5 is a 2U2S rack-mounted server, designed for meeting the requirements of Internet, IDC (Internet Data Center), cloud computing, enterprise market and telecommunication services, on the basis of the new generation of Intel® Xeon® scalable processors. This product meets the business requirements of high network bandwidth, high computing performance, large memory capacity and large storage capacity, and provides a good solution for customers with density and storage requirements. It is especially suitable for business intelligence, financial services, public cloud and private cloud applications that have stringent requirements on servers.



Figure 2-1 NF5266M5 External View

2.2 Features and Specifications

2.2.1 Product Features

Inspur server NF5266M5 has a very high computing density, and meets the needs of cloud computing data center's multiple application scenarios, with different drive configuration, high scalability, and flexible network deployment capability. Inspur uses the ultimate design concept in terms of performance, scalability, usability and managability to maintain the consistently high quality and high reliability of Inspur servers.

Performance

NF5266M5 is designed on the basis of the new generation of Intel® Xeon® Skylake & Cascadelake scalable processors. One single CPU has up to 24 cores and 48 threads, and supports up to TDP165W, 36MB L3 cache and two 10.4 GT/s UPI interconnection links, with

high processing performance.

Supports 12 2933 MT/s DDR4 ECC memories. The memory supports RDIMM type, which provides excellent speed, high availability and large capacity.

Supports 4 hot-swappable NVMe SSDs, which can provide 10 times more IOPS than high-end enterprise-class SATA SSDs; supports 24 hot-swappable hard drives in the front.

Scalability

Supports up to 24*3.5" hard drive + 4*2.5" hard drive or 24*2.5" hard drive + 4*2.5" hard drive, and 2 internal SATA M.2 SSDs.

Supports free switch between the OCP card and PHY card, provides 1G, 10G, 25G and 40G network interface options, and provides a more flexible network structure for applications.

Supports up to 4 standard PCIe 3.0 expanders, to further improve the I/O performance.

Usability

NF5266M5 provides several features to enhance usability and improve system stability.

Based on the humanized design concept, the entire system can achieve tool-free maintenance. Through structure optimization, rapid disassembly and assembly is achieved, and the operation and maintenance time is greatly shortened.

With Inspur's unique intelligent control technology and advanced air-cooling system, it can achieve the best operating environment, and ensure the stable operation of the system.

Hot-swappable hard drives; supports RAID 0/1/5/10 to provide RAID Cache; supports super-capacitor power-down data protection.

Using the latest BMC technology, technicians can locate issues through Web management interface, fault diagnosis LED and other guidance devices, mark the faulty machine with the UID LED on the front panel, and quickly find the component that has failed (or is failing), which simplifies product maintenance, speeds up problem resolution, and increases system usability.

The BMC monitors system parameters and sends alarm information in advance, enabling technicians to take appropriate measures to ensure stable operation of the machine and reduce the possibility of downtime.

Managbility

Inspur's power management technology helps users to accurately monitor and control system power consumption. With Node Manager 4.0 technology, comprehensive power management and control can be effectively implemented to further improve the energy efficiency of the overall IT architecture.

Providing a fast optical path diagnosis method for the server, the use of LEDs not only greatly saves space on the motherboard, but also displays the server power-on progress more visually and quickly, which brings convenience for server debugging, and enables the maintenance personnel to quickly find the equipment to be maintained.

Energy efficiency

Provides 800W/1300W platinum power supply with up to 94% efficiency at 50% load.

Supports 1+1 redundant power supplies to improve power conversion efficiency.

High-efficient single-board VRD power supply reduces DC to DC losses.

Supports system fan intelligent speed regulation and CPU intelligent frequency adjustment to save energy.

All-round optimized system cooling design and high-efficient energy-saving system fans reduce system cooling energy consumption.

Safety

Implements firmware encryption/digital signature to prevent illegal writing of unknown firmware.

2.2.2 Product Specifications

Table 2-1

Component	Description
Form	2U rack-mounted server
Processor	Supports 1 or 2 Intel® Xeon® 4100/5100/6100 series Skylake scalable processors; Supports 1 or 2 Intel® Xeon® 4200/5200/6200/8200 series Cascadelake scalable processors
	Two UPI interconnection links, up to 10.4GT/s per link
	Maximum 165W TDP
Chipset	Intel LBG-2 (C622)
GPU	Integrated in Aspeed 2500 chip, supports up to 1280*1024 resolution, 32MB video memory
Memory	Supports up to 12 memories. Each processor supports 6 memory channels, and the maximum memory speed is 2933MT/s.
Maximum memory capacity	RDIMM/LRDIMM: Two processors support up to 12*64GB memory modules with a capacity of 768GB
Storage	Front panel: 24 * 3.5" SATA/SAS drive, supporting hot swap
	Rear panel: 4 * 2.5" SATA/NVMe SSD, supporting hot swap
M.2	Supports up to 2 80MM SATA M.2 SSDs
Storage controller (24i Raid/SAS configuration)	Front RAID/SAS controller
	9305-24i, 3154-24i
	Rear RAID controller
	PM8060-8i, 9460-8i, 9361-8i

Storage controller (Expander configuration)	PM8060-8i, 9460-8i, 9361-8i, 3008IR, 3008-IT, 3108
Network interface	OCP/PHY card: 10Gb/s, 25Gb/s
	Standard PCIe card: 1Gb/s, 10Gb/s, 25Gb/s, 100Gb/s
I/O expansion slot	Supports up to 4 standard PCIe cards and 1 OCP card slot (connector A+C)
	CPU1 can expand PCIe 3.0 x32, supporting 2 HHHL PCIe 3.0 x16 cards
	CPU0 can expand PCIe 3.0 x16, supporting 2 HHHL PCIe 3.0 x8 cards
I/O	2 front USB 3.0 ports, 2 rear USB 3.0 ports
	1 front VGA port, 1 rear VGA port
	1 rear RJ45 IPMI port
Fan	5 hot-swappable N+1 redundant 6038 fans
Power supply	Supports 1+1 redundant power supply 1300W
	Supports CRPS, PMBUS, Node Manager 4.0 functions
System management	Integrates 1 independent 1000Mbps network interface for IPMI2.0 remote management
Operating system	Windows 2012R2/2016
	Redhat 6.9/7.4
	Suse 12
	CentOS 7.2/7.4
	Oracle Linux 7
Operating temperature	5°C -35°C
Storage & transportation temperature	-40°C -60°C
Operating humidity	20% -80% relative humidity
Storage & transportation humidity	20% -93% (40°C) relative humidity

2.3 Power Efficiency

Table 2-2

Efficiency Level	Rated Power	Efficiency				PF
		@10% Load	@20% Load	@50% Load	@100% Load	
Platinum	800W		90%	94%	91%	0.98
	1300W		90%	94%	91%	0.98
Titanium	1300W	90%	94%	96%	91%	0.98

Table 2-3

EU Regulation 2019/424 Server configurations	High-end performance configuration	Low-end performance configuration
(h) idle state power	128.3W	95.2W
(i) list of all components for additional idle power allowances, if any (additional PSU, HDDs or SSDs, additional memory, additional buffered DDR channels, additional I/O devices);	See Below	See Below
(j) maximum power, expressed in Watts and rounded to the first decimal place;	525.7W	200.6W
(k) declared operating condition class, as detailed in Table 6;	A2	A2
(l) idle state power (Watts) at the higher boundary temperature of the declared operating condition class;	157.8W	147.6W
(m) the active state efficiency and the performance in active state of the server;	37.7	20.6

Table 2-4

(i) List of components for additional power allowance		High-end performance configuration	Low-end performance configuration
CPU Performance	1 socket: 10 × Perf CPU W	103.46W	18.2W
	2 socket: 7 × Perf CPU W		
Additional PSU	10 W per PSU	10W	10W
HDD or SSD	5.0 W per HDD or SSD	10W	10W
Additional memory	0.18 W per GB	137.52W	33.84W
Additional buffered DDR channel	4.0 W per buffered DDR channel	16W	16W
Additional I/O devices	< 1 Gb/s: No Allowance	0	0
	= 1 Gb/s: 2.0 W/Active Port		
	> 1 Gb/s and < 10 Gb/s: 4.0 W/Active Port		
	≥ 10 Gb/s and < 25Gb/s: 15.0 W/Active Port		
	≥ 25 Gb/s and < 50Gb/s: 20.0 W/Active Port		
	≥ 50 Gb/s 26.0 W/Active Port		
Total idle state power allowed		314.98W	126.04W

3 Component Identification

3.1 Front and Rear Panel Components

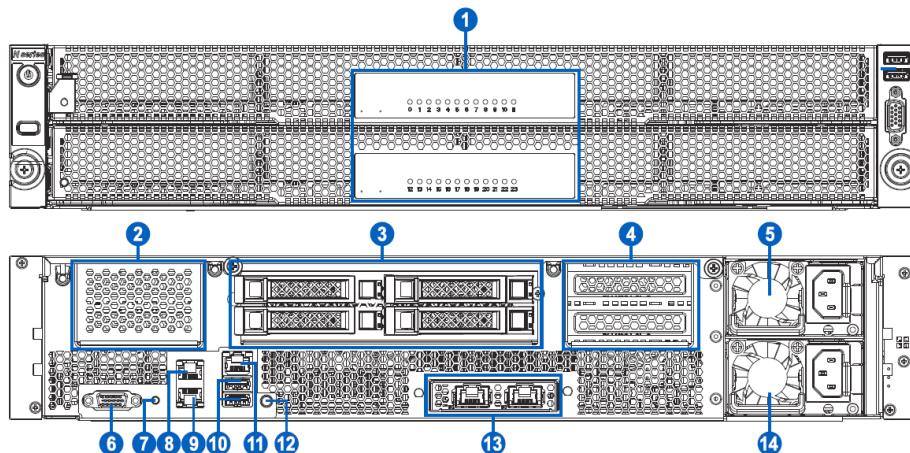

Figure 3-1

Table 3-1

Item	Description
1	Front HDD LED
2	PCI slot (CPU1)
3	Drive module
4	PCI slot (CPU0)
5	PSU0
6	VGA port
7	RST button
8	I2C0/1 port
9	I2C2/3 port
10	USB3.0 port
11	BMC port
12	UID button
13	OCP expansion card
14	PSU1

● Front Drive Tray LEDs

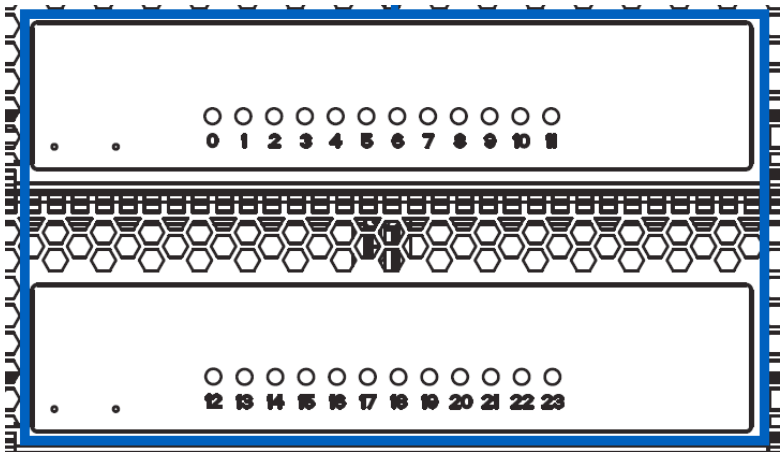

Figure 3-2

Table 3-2

Description	Status & Interpretation
Activity status LED	Steady green: Normal Flashing green (0.5 times/sec): Rebuilding or ongoing Replace Member operation Flashing green 4HZ: Data transmitting Flashing amber: Fault alarm Off: HDD not in position

● Rear Drive Tray LEDs



Figure 3-3

Table 3-3

Item	Description	Status & Interpretation
1	Activity status LED	Steady green: Normal Flashing green: Read and write activity
2	Fault alarm LED	Steady red: A failure occurs Steady blue: Disk positioning Steady purple: RAID rebuilding

3.2 Left and Right Ear Components

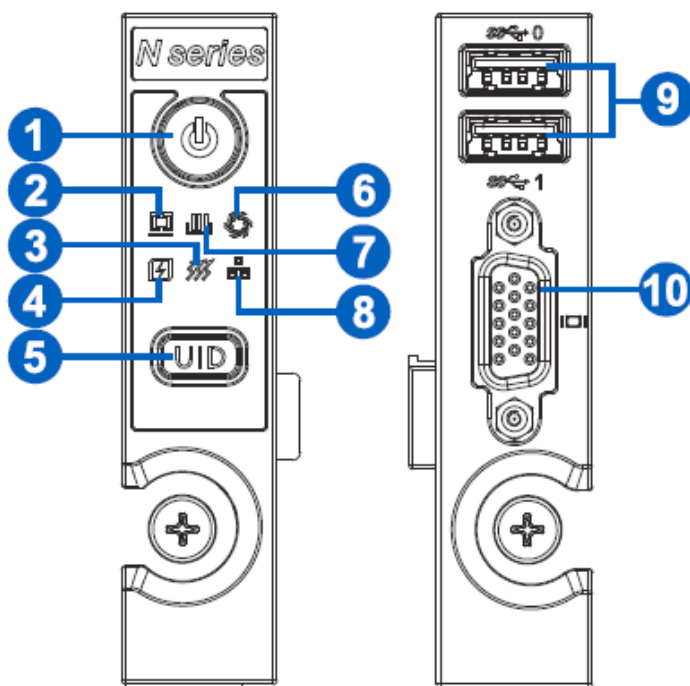

Figure 3-4

Table 3-4

Item	Description
1	Power button
2	System status LED
3	System overheat LED
4	Power failure LED
5	UID RST button
6	Fan failure LED
7	Memory failure LED
8	Network status LED
9	USB3.0 port (2)
10	VGA port

3.3 Motherboard Components

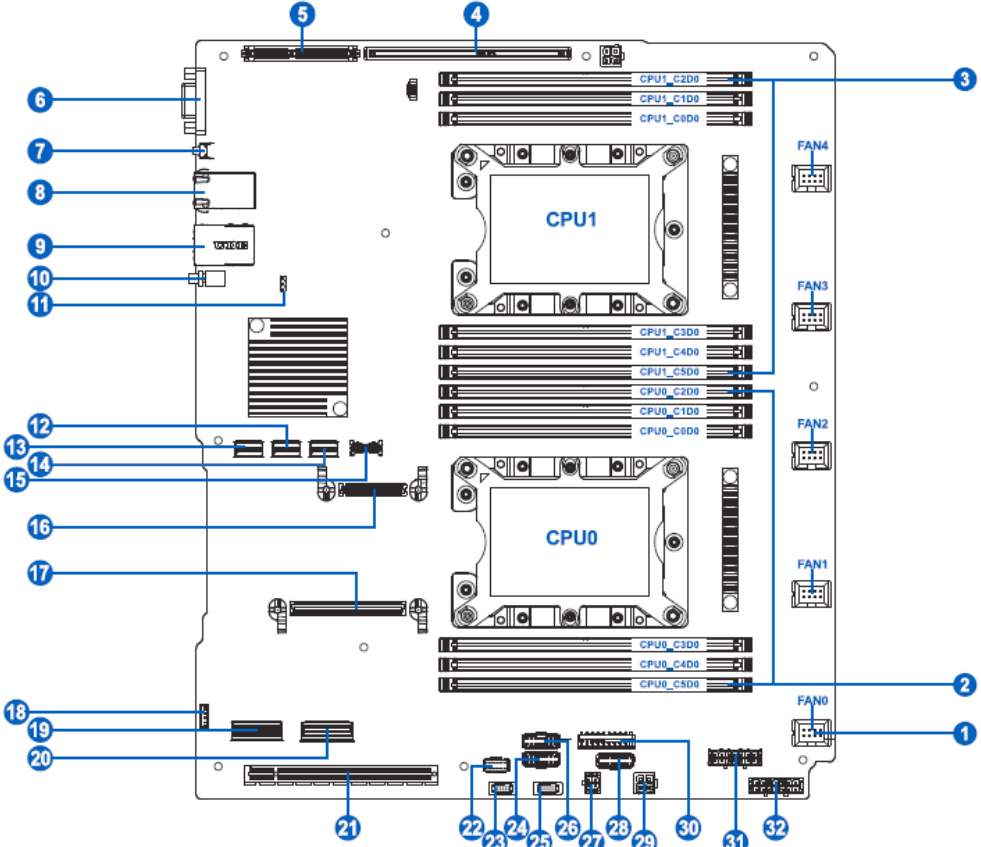

Figure 3-5

Table 3-5

Item	Description
1	System fan connectors
2	DIMM slots (CPU0)
3	DIMM slots (CPU1)
4	PCIE_CPU1 slot
5	M.2 connector
6	VGA port
7	BMC_RST button
8	JBOD_I2C connector
9	USB3.0+MLAN port
10	UID LED
11	CLR_CMOS

Item	Description
12	SLIM_SATA0-3 connector
13	SLIM_SSATA2-5 connector
14	SLIM_SATA4-7 connector
15	Front panel right ear connector
16	OCPC connector
17	OCPA_CPU0 connector
18	RAID_KEY
19	SLIM_NVME2/3
20	SLIM_NVME0/1
21	PCIE0_CPU0 slot
22	PSU_CONTROL connector
23	LED_BOARD1 connector
24	BP_2_3_4 connector
25	LED_BOARD0 connector
26	BP_0_1_2 connector
27	PWR_U.2 connector
28	Front panel left ear connector
29	PWR_X16 RISER connector
30	TCP/TPM connector
31	PSU1 connector
32	PSU0 connector

3.4 Motherboard Jumper Introduction

See [3.3 Motherboard Components] for the jumper position.

Table 3-6

Item	Description	Function
CLR_CMOS	CMOS clear jumper	Short-circuit pin1-2, normal status; Short-circuit pin2-3, clear CMOS.



Note:

It is required to shut down the system, as well as disconnect the power supply during CMOS clearing. Hold for 5 seconds after short-circuiting pin2-3, and then short-circuit pin1-2 (default setting) to restore to its original status.

4 Operations

4.1 Power up the Server

Insert the power cord plug, then press the Power Button.

4.2 Power down the Server

 **WARNING:** To reduce the risk of personal injury, electric shock, or damage to the equipment, remove the power cord to remove power from the server. The front panel Power Button does not completely shut off system power. Portions of the power supply and some internal circuitry remain active until AC power is removed.

 **IMPORTANT:** If installing a hot-plug device, it is not necessary to power down the server.

1. Back up the server data.
2. Shut down the operating system.
3. Disconnect the power cords.

The system is now without power.

4.3 Extend the Server from the Rack

1. Remove the screws from the left and right handles of the server.
2. Extend the server from the rack.

 **WARNING:** To reduce the risk of personal injury or equipment damage, be sure that the rack is adequately stabilized before extending a component from the rack.

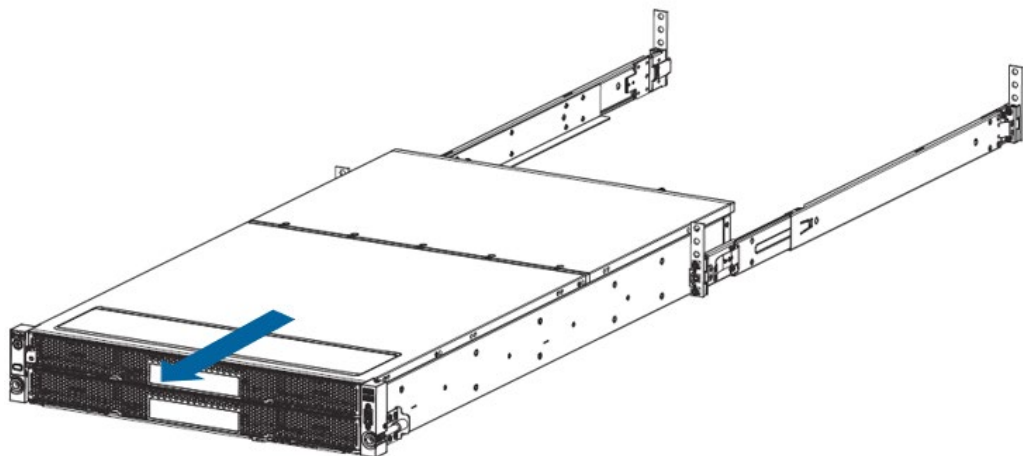



Figure 4-1

3. After performing the installation or maintenance procedure, slide the server back into the rack, and then use a screwdriver to lock the screws.

 **WARNING:** To reduce the risk of personal injury, be careful when sliding the server into the rack. The sliding rails could pinch your fingers.

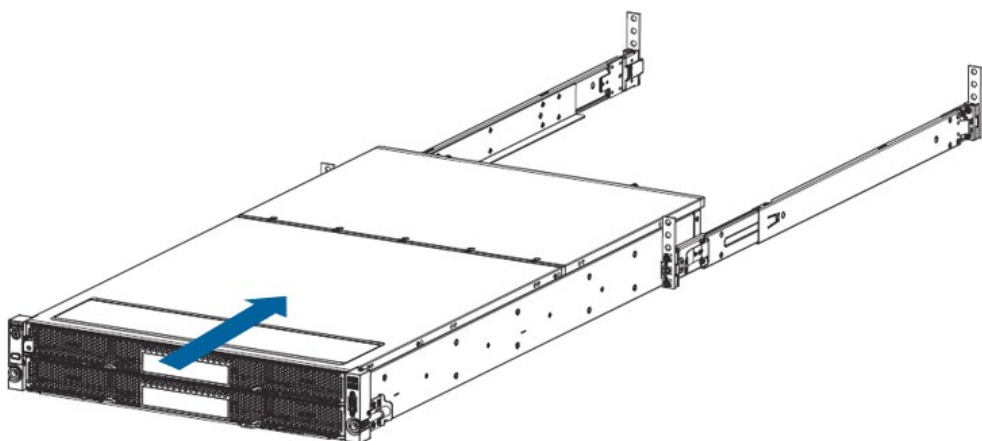

Figure 4-2

5 Setup

5.1 Optimum Environment

When installing the server in a rack, select a location that meets the environmental standards described in this section.

5.1.1 Space and Airflow Requirements

To allow for servicing and adequate airflow, observe the following space and airflow requirements when deciding where to install a rack:

- Leave a minimum clearance of 63.5 cm (25 in) in front of the rack.
- Leave a minimum clearance of 76.2 cm (30 in) behind the rack.
- Leave a minimum clearance of 121.9 cm (48 in) from the back of the rack to the back of another rack or row of racks.

Inspur Servers draw in cool air through the front door and expel warm air through the rear door. Therefore, the front and rear rack doors must be adequately ventilated to allow ambient room air to enter the cabinet, and the rear door must be adequately ventilated to allow the warm air to escape from the cabinet.



CAUTION: To prevent improper cooling and damage to the equipment, do not block the ventilation openings.

When vertical space in the rack is not filled by a server or rack component, the gaps between the components cause changes in airflow through the rack and across the servers. Cover all gaps with blanking panels to maintain proper airflow.



CAUTION: Always use blanking panels to fill empty vertical spaces in the rack. This arrangement ensures proper airflow. Using a rack without blanking panels results in improper cooling that can lead to damage.

CAUTION: If a third-party rack is used, observe the following additional requirements to ensure adequate airflow and to prevent damage to the equipment:

- Front and rear doors—If the 42U rack includes closing front and rear doors, you must allow 5,350 sq cm (830 sq in) of holes evenly distributed from top to bottom to permit

adequate airflow (equivalent to the required 64 percent open area for ventilation).

- Side—The clearance between the installed rack component and the side panels of the rack must be a minimum of 7 cm (2.75 in).
-

5.1.2 Temperature Requirements

To ensure continued safe and reliable equipment operation, install or position the system in a well-ventilated, climate-controlled environment.

The maximum recommended ambient operating temperature (TMRA) for most server products is 35°C (95°F). The temperature in the room where the rack is located must not exceed 35°C (95°F).



CAUTION: To reduce the risk of damage to the equipment when installing third-party options:

- Do not permit optional equipment to impede airflow around the server or to increase the internal rack temperature beyond the maximum allowable limits.
 - Do not exceed the manufacturer's TMRA.
-

5.1.3 Power Requirements

Installation of this equipment must comply with local and regional electrical regulations governing the installation of information technology equipment by licensed electricians. This equipment is designed to operate in installations covered by NFPA 70, 1999 Edition (National Electric Code) and NFPA-75, 1992 (code for Protection of Electronic Computer/Data Processing Equipment). For electrical power ratings on options, refer to the product rating label or the user documentation supplied with that option.



WARNING: To reduce the risk of personal injury, fire, or damage to the equipment, do not overload the AC supply branch circuit that provides power to the rack. Consult the electrical authority having jurisdiction over wiring and installation requirements of your facility.



CAUTION: Protect the server from power fluctuations and temporary interruptions with a regulating uninterruptible power supply (UPS). This device protects the hardware from damage caused by power surges and voltage spikes and keeps the system in operation during a power failure.

When installing more than one server, you may need to use additional power distribution devices to safely provide power to all devices. Observe the following guidelines:

- Balance the server power load between available AC supply branch circuits.
- Do not allow the overall system AC current load to exceed 80 percent of the branch circuit AC current rating.
- Do not use common power outlet strips for this equipment.
- Provide a separate electrical circuit for the server.

5.1.4 Electrical Grounding Requirements

The server must be grounded properly for optimal operation and safety. In the United States, you must install the equipment in accordance with NFPA 70, 1999 Edition (National Electric Code), Article 250, as well as any local and regional building codes. In Canada, you must install the equipment in accordance with Canadian Standards Association, CSA C22.1, and Canadian Electrical Code. In all other countries, you must install the equipment in accordance with any regional or national electrical wiring codes, such as the International Electrotechnical Commission (IEC) Code 364, parts 1 through 7. Furthermore, you must be sure that all power distribution devices used in the installation, such as branch wiring and receptacles, are listed or certified grounding-type devices.

Because of the high ground-leakage currents associated with multiple servers connected to the same power source, Inspur recommends the use of a PDU that is either permanently wired to the building's branch circuit or includes a nondetachable cord that is wired to an industrial-style plug. NEMA locking-style plugs or those complying with IEC 60309 are considered suitable for this purpose. Using common power outlet strips for the server is not recommended.

5.2 Rack Warnings

WARNING: To reduce the risk of personal injury or damage to the equipment, please be sure of the following:

- The leveling jacks are extended to the floor.
- The full weight of the rack rests on the leveling jacks.

- The stabilizing feet are attached to the rack if it is a single-rack installation.
 - The racks are coupled together in multiple-rack installations.
 - Only one component is extended at a time. A rack may become unstable if more than one component is extended for any reason.
-



WARNING: To reduce the risk of personal injury or equipment damage when unloading a rack:

- At least two people are needed to safely unload the rack from the pallet. An empty 42U rack can weigh as much as 115 kg (253 lb), can stand more than 2.1 m (7 ft) tall, and may become unstable when being moved on its casters.
 - Never stand in front of the rack when it is rolling down the ramp from the pallet. Always handle the rack from both sides.
-

5.3 Identifying the Contents of the Server Shipping Carton

Unpack the server shipping carton and locate materials and documentation necessary for installing the server. All the rack mounting hardware necessary for installing the server into the rack is included with the rack or the server.

The contents of the server shipping carton include:

- Server
- Power cord
- Hardware documentation and software products
- Rack-mounting hardware

In addition to the supplied items, you may need:

- Operating system or application software
- Hardware options

5.4 Installing Hardware Options

Install any hardware options before initializing the server. For options installation information, refer to the option documentation. For server-specific information, refer to “Hardware options installation”.

5.5 Installing the Server into the Rack



CAUTION: Always plan the rack installation so that the heaviest item is on the bottom of the rack. Install the heaviest item first, and continue to populate the rack from the bottom to the top.

1. Install the server and cable management arm into the rack. For more information, see the installation instructions attached with the 2U Quick Deploy Rail System.
2. Connect peripheral devices to the server. For connector identification information, see “Rear panel components” in this guide.



WARNING: To reduce the risk of electric shock, fire, or damage to the equipment, do not plug telephone or telecommunications connectors into RJ-45 connectors.

3. Connect the power cord to the rear of the server.
4. Connect the power cord to the AC power source.



WARNING: To reduce the risk of electric shock or damage to the equipment:

- Do not disable the power cord grounding plug. The grounding plug is an important safety feature.
- Plug the power cord into a grounded (earthed) electrical outlet that is easily accessible at all times.
- Unplug the power cord from the power supply to disconnect power to the equipment.
- Do not route the power cord where it can be walked on or pinched by items placed against it. Pay particular attention to the plug, electrical outlet, and the point where the cord extends from the server.

5.6 Installing the Operating System

To operate properly, the server must have a supported operating system installed. For the latest information on supported operating systems, refer to the Inspur website (<http://www.inspur.com/eportal/ui?pageId=444443>).

6 Hardware Options Installation

Introduction

If more than one option is being installed, read the installation instructions for all the hardware options and identify similar steps to streamline the installation process.

 **WARNING:** To reduce the risk of personal injury from hot surfaces, allow the drives and the internal system components to cool before touching them.

 **CAUTION:** To prevent damage to electrical components, properly ground the server before beginning any installation procedure. Improper grounding can cause electrostatic discharge.

6.1 Processor Option

The server supports single- and dual-processor operation.

 **CAUTION:** To avoid damage to the processor and system board, only authorized personnel should attempt to replace or install the processor in this server.

To help avoid damage to the processor and system board, do not install the processor without using the processor installation tool.

 **CAUTION:** To prevent possible server malfunction and damage to the equipment, multiprocessor configurations must contain processors with the same part number.

 **CAUTION:** To install a faster processor, update the system ROM before installing the processor.

To install the component:

1. Power down the server.
2. Extend the server from the rack.
3. Remove the access panel.
4. Remove the air baffle.
5. Remove the heatsink.

6. Install the processor:

Step 1: Open the two levers of the CPU socket, and open the fixing plate.

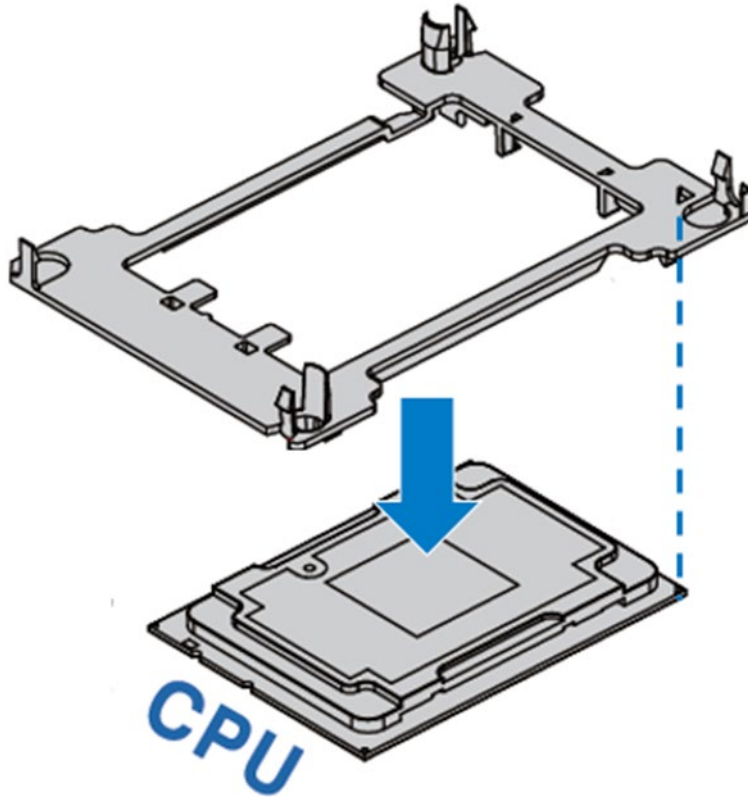

Figure 6-1

Step 2: Align the heatsink position marked by “1” with the Clip’s triangle mark, vertically align the mounting holes on the heatsink with those on the Clip, and assemble the heatsink and Clip together.

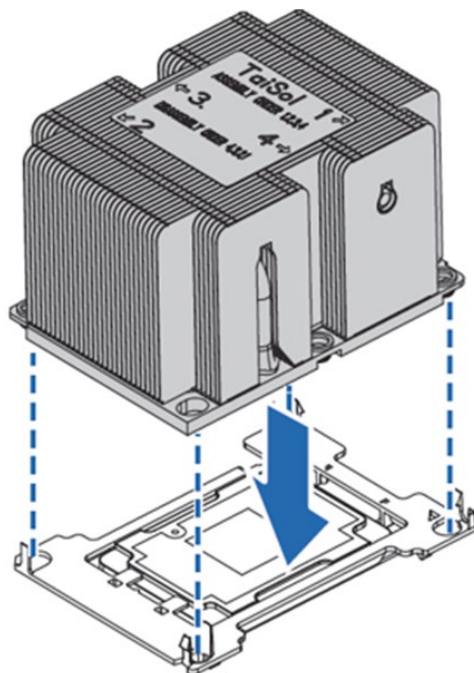

Figure 6-2

Step 3: Install the assembled heatsink module onto the CPU socket, and the position marked by “1” should be aligned with the triangle mark on the CPU socket. Tighten the screws according to the sequence of 1, 2, 3 and 4.

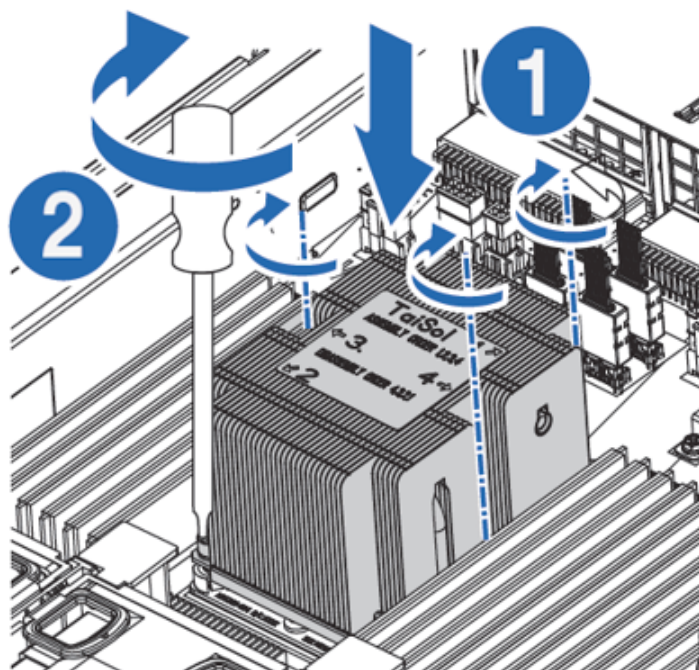

Figure 6-3

**Notes:**

- It is required to coat thermal grease evenly onto the contact position between CPU heatsink and CPU.
- The pins of the processor socket are easily damaged. If any pins are damaged, you may need to replace the motherboard.

6.2 Memory Option

IMPORTANT:

This server does not support mixing DIMMs. Attempting to mix the DIMMs of two different types may cause the server stops running during initialization.

All DIMMs installed in the server must be the same type.

- DIMM slot layout is as shown in the following figure:

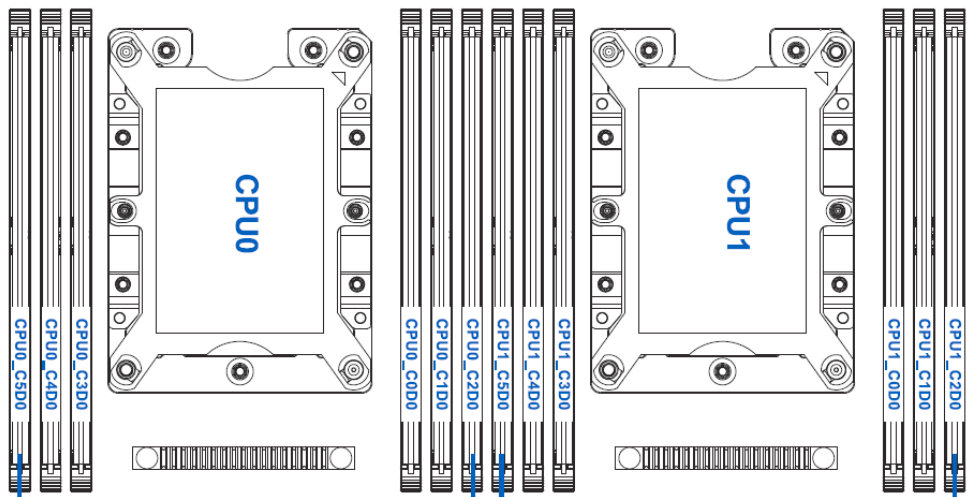

Figure 6-4

Step 1: Open the lock tabs on both ends of the DIMM slot.

Step 2: Align the bottom key with the receptive point on the slot, press both ends of the DIMM with your thumbs. Insert the DIMM into the slot completely, and the lock tabs will automatically secure the DIMM, locking it into place.

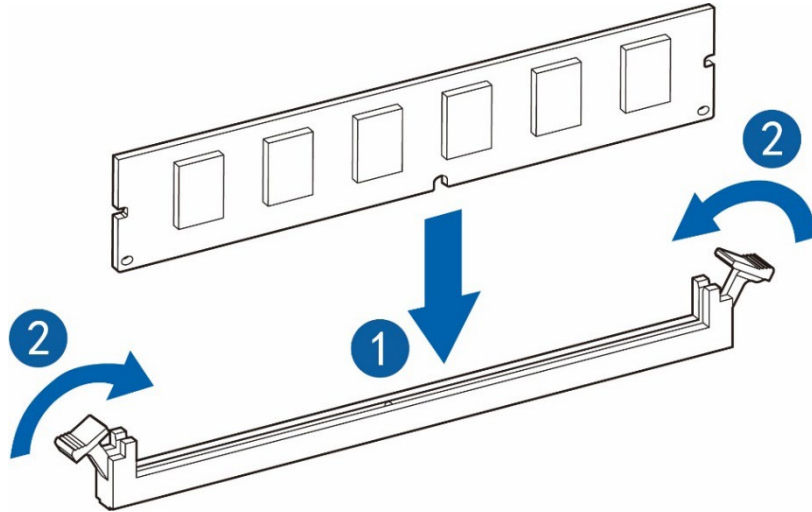

Figure 6-5

6.3 Hot-plug HDD Option

CAUTION: For proper cooling, do not operate the server without the access panel, baffles, expansion slot covers, or blanks installed. If the server supports hot-plug components, minimize the amount of time the access panel is open.

1. Check the status of the hard disk drive from the hot-plug HDD LED.
2. Back up all data on the hard disk drive.
3. Remove the hard disk drive.

Step 1: Press the HDD panel button.

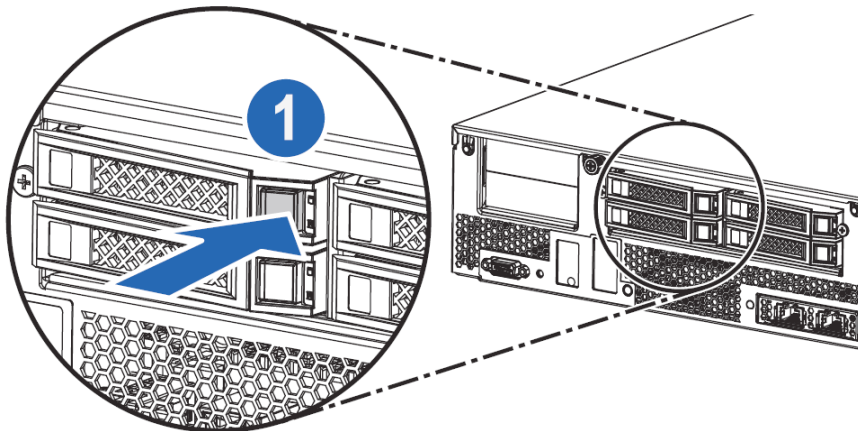

Figure 6-6

Step 2: The lever on the HDD tray pops up automatically, pull it outwards and remove the HDD tray.

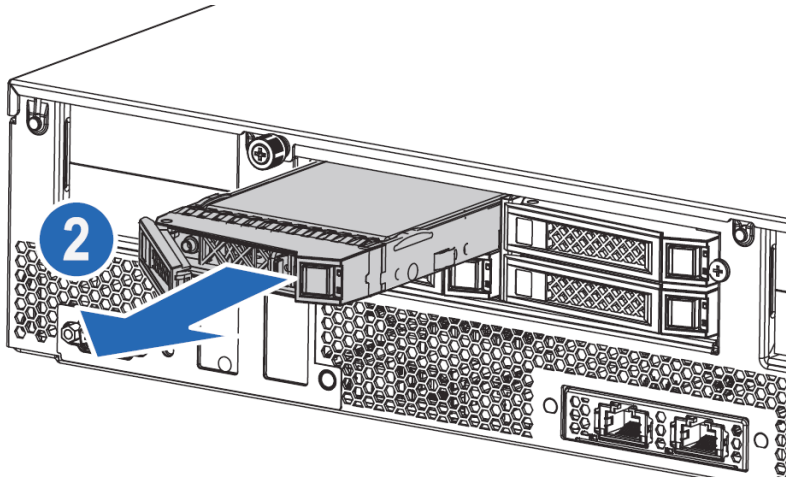

Figure 6-7

Step 3: Remove the four screws on the two sides of the tray, and remove the old HDD from the tray.

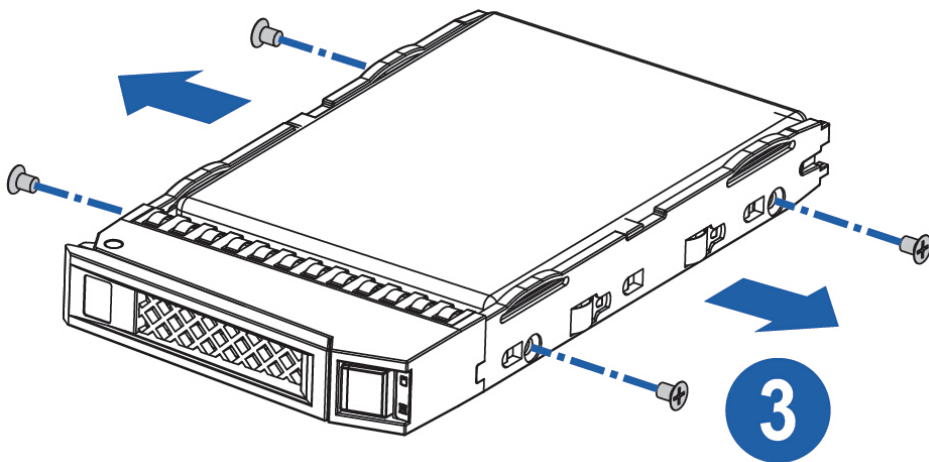

Figure 6-8

Step 4: Install the new HDD into the tray, install the tray into the chassis, and lock the lever firmly.

Remove the front HDD:

1. Check the status of the hard disk drive from the hot-plug HDD LED.
2. Back up all data on the hard disk drive.
3. Remove the hard disk drive.

Step 1: Open the lock of the corresponding HDD tier.

Step 2: Pull out the corresponding HDD tray.

Step 3: Remove the old HDD from the tray.

Step 4: Install a new HDD into the tray, and push the tray back into the chassis.

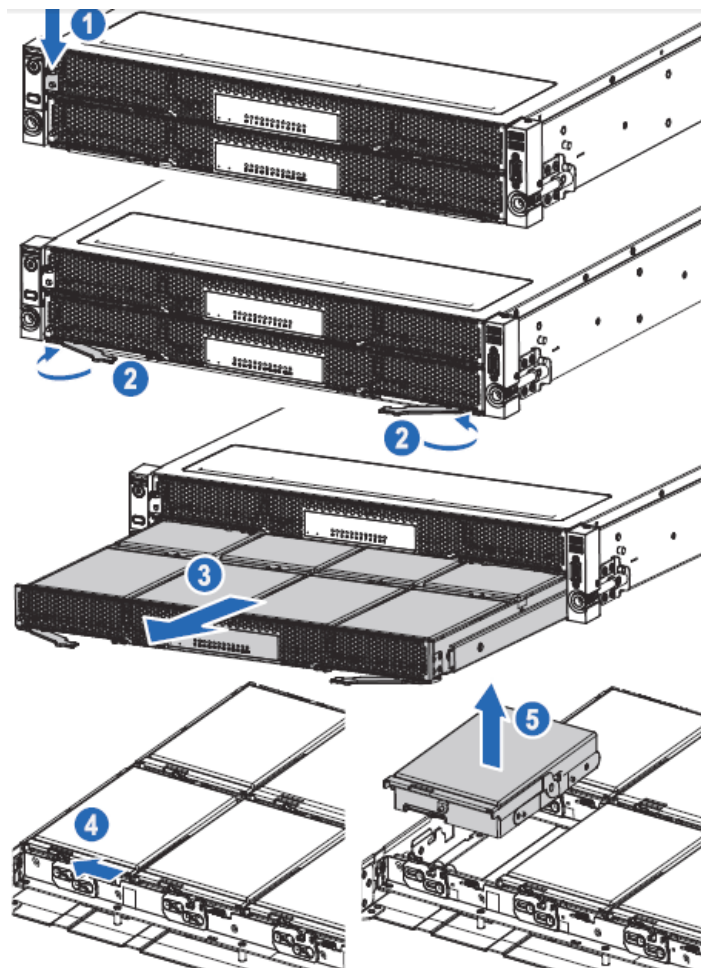

Figure 6-9

6.4 Redundant Hot-plug Power Supply Option

CAUTION: To prevent improper cooling and thermal damage, do not operate the server unless all bays are populated with either a component or a blank.

1. Access the product rear panel.
2. Remove the power supply blank.

WARNING: To reduce the risk of personal injury from hot surfaces, allow the power supply or power supply blank to cool before touching it.

3. Remove the power supply from the chassis.

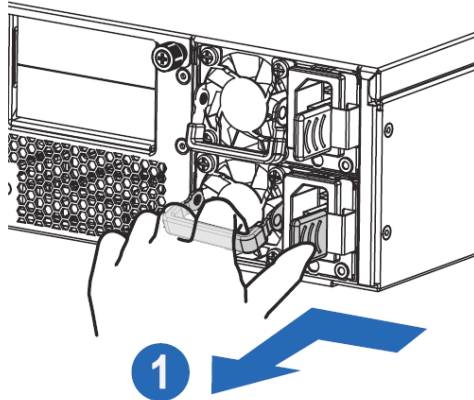

Figure 6-10

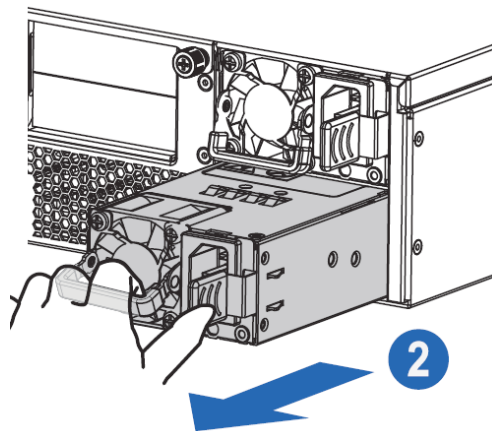

Figure 6-11

6.5 Air Baffle Option

CAUTION: For proper cooling, do not operate the server without the access panel, baffles, expansion slot covers, or blanks installed. If the server supports hot-plug components, minimize the amount of time the access panel is open.

1. Power down the server.
2. Extend the server from the rack.

WARNING: To reduce the risk of personal injury from hot surfaces, allow the machine to

⚠ cool before touching it.

Step 1: Remove the cable/rear HDD bracket above the air baffle.

Step 2: Remove the front air baffle vertically according to the direction of the arrow in the following figure.

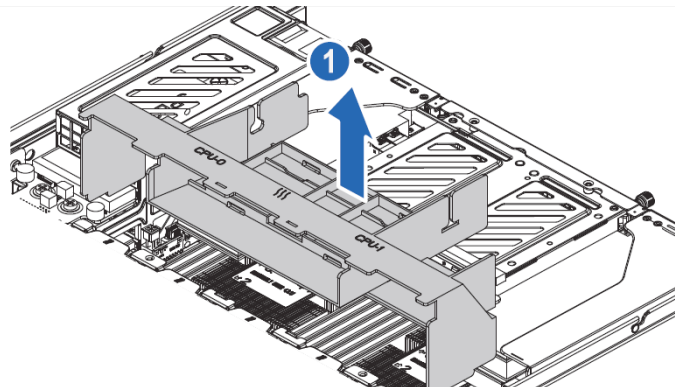

Figure 6-12

6.6 TPM Option

1. Power down the server.
2. Extend the server from the rack.
3. Remove the access panel.
4. Remove the air baffle.
5. Remove the TPM.

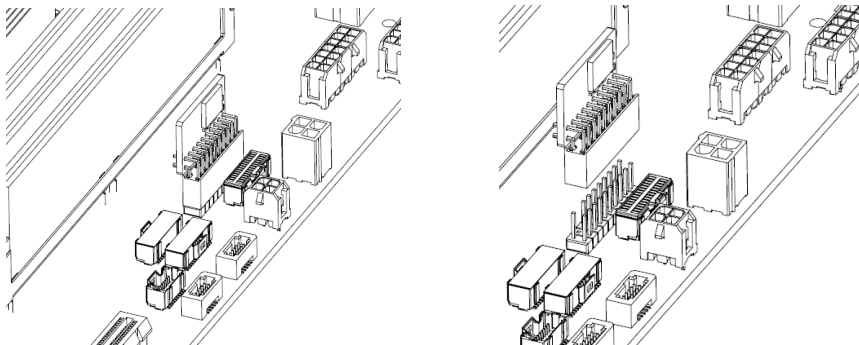

Figure 6-13

6.7 M.2 SSD Option

1. Power down the server.

2. Extend the server from the rack.
3. Remove the access panel.
4. Remove the corresponding node.
5. Remove the bracket of the PCIE riser card.
6. Remove the bracket of the M.2 riser card.
7. Loosen the screw and remove the M.2 SSD.

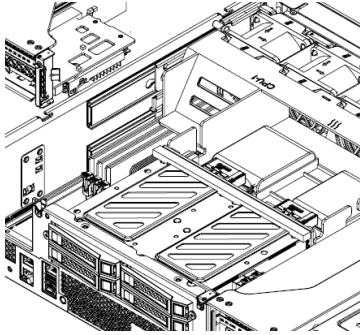

Figure 6-14

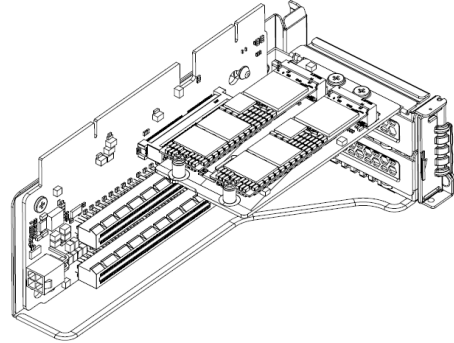

Figure 6-15

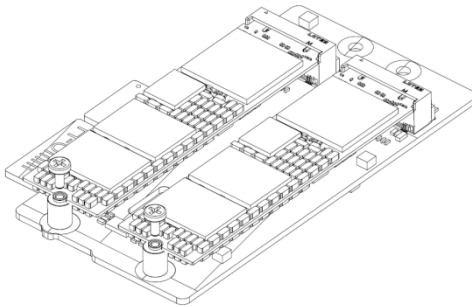

Figure 6-16

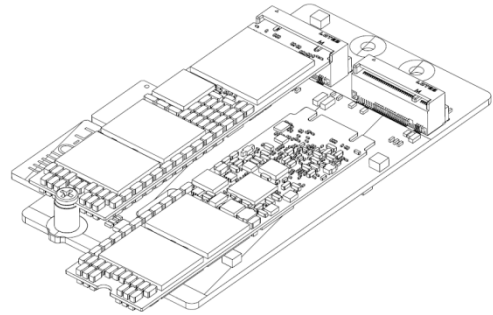

Figure 6-17

6.8 OCP/PHY Card Option

1. Power down the server.
2. Extend the server from the rack.
3. Remove the access panel.
4. Remove the corresponding node.
5. Remove the OCP/PHY card vertically as shown below, and replace it with a new one.

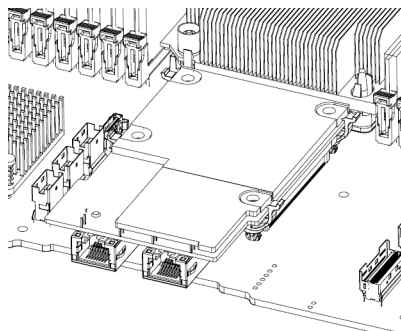

Figure 6-18

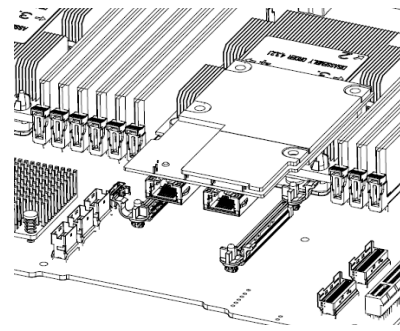

Figure 6-19

7 Cabling

Cable routing diagram of the configuration equipped with external SAS card

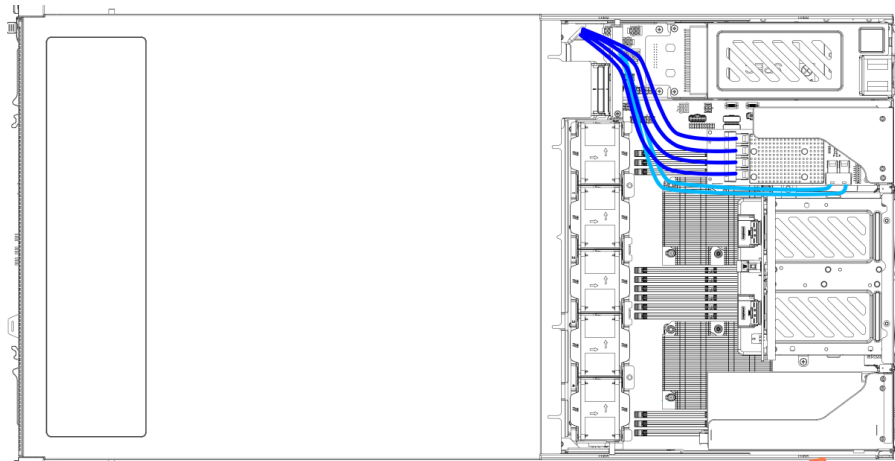

Figure 7-1



CAUTION: Please route the cables according to the purchased machine configuration.

8 BIOS Setup

BIOS is the basic input/output system, which is the basic program code loaded in the motherboard chipset. It stores the computer's most important input/output program, POST program and system auto-boot program. It provides the most basic and most direct hardware settings and control, detects the boot device, boots the system or other preboot execution environment.

Inspur Purley platform server is developed on the basis of Insyde Codebase, supporting Legacy and UEFI operating environments, with abundant in-band and out-of-band configuration functions and scalability. It can meet the customization needs of different customers.



Notes:

- 1. We recommend that you record the original BIOS settings before you modify them so it can safely revert to its previous state if required. If there is an exception, such as failure to boot, caused by changing the BIOS settings, users can try to recover it through the Clear CMOS operation.**
- 2. The factory default settings are the optimal settings. It is advised not to alter the parameters before understanding their denotations.**
- 3. The common settings are introduced in detail in this chapter, but less common ones are not.**
- 4. The BIOS content varies according to the particular configuration of the products; hence the detailed introduction is elided.**

8.1 Common Operations

8.1.1 Login to BIOS Interface

Power on the server. The system will then start to boot. When the following content appears below Inspur logo on the screen: "Press to SETUP or <TAB> to POST or <F11> to Boot Menu or <F12> to PXE Boot." Press DEL key. When "Entering Setup ..." appears in the lower right corner of the screen, it will enter the BIOS setup soon. In the BIOS main menu, you could select the subitem through direction keys to enter the submenu.

Other hotkeys function:

- Press DEL to enter BIOS Setup interface.
- Press TAB to display the system information during POST.
- Press F11 to enter the boot management interface, select the boot device.
- Press F12 to boot the PXE.

Table 8-1 BIOS Setup Interface Control Key Instruction Table

Key	Function
<Esc>	Exit or return from submenu to main menu
<<-> or <->>	Select a menu
<↑> or <↓>	Move the cursor up or down
<Home> or <End>	Move the cursor to the top or bottom of the screen
<+> or <->	Select the previous or next numerical value or setting of the current one
<F1>	Help
<F2>	Restore to the last configuration
<F9>	Restore to the default configuration
<F10>	Save and exit
<Enter>	Execute commands or select a submenu

 **Note:** Options in grey are not available. Options with symbol “▶” have a sub-menu.

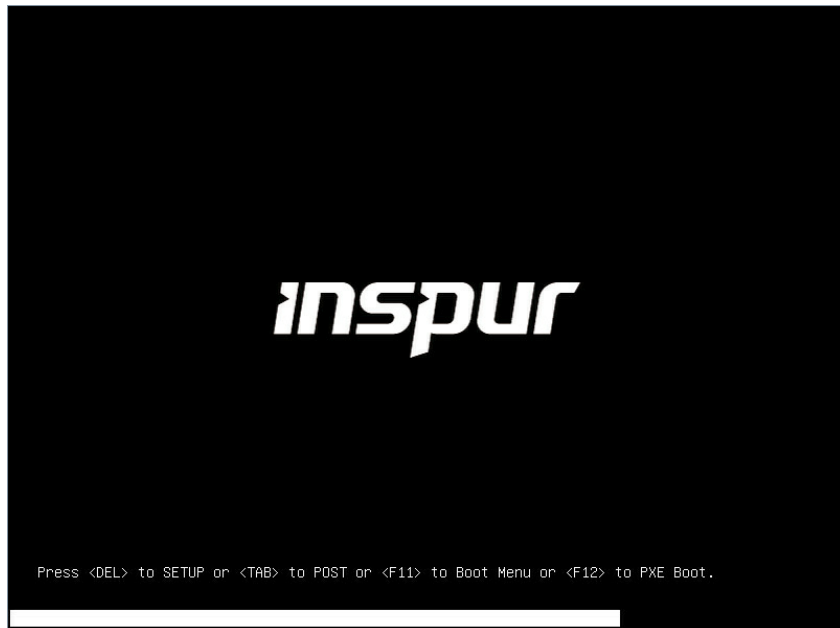

Figure 8-1

8.1.2 UEFI/Legacy Mode Switch

Login to the BIOS Setup interface, select “Advanced -> CSM Configuration”. Press Enter, to set the Boot Mode (UEFI Mode/Legacy Mode). Set the Option ROM execution mode of Network, Storage, Video OPRM Policy and Other PCI devices, as shown in the following figure.

At present, Inspur Purley platform servers are set to UEFI Mode by default. Compared with Legacy mode, UEFI mode has many advantages: It supports boot from the GPT disk which is larger than 2.2T, supports IPv6/IPv4 PXE boot, and provides UEFI Shell environment. This option can be set according to customer’s demand.

If the Boot Mode is set to Legacy Mode, the Option ROM execution mode of Network, Storage, Video OPRM Policy and Other PCI devices must be set to Legacy.

If the Boot Mode is set to UEFI Mode, the Option ROM execution mode of Network must be set to UEFI, and the Option ROM execution mode of Storage, Video OPRM Policy and Other PCI devices is suggested to set to UEFI. If there are special requirements, it can be set to Legacy.

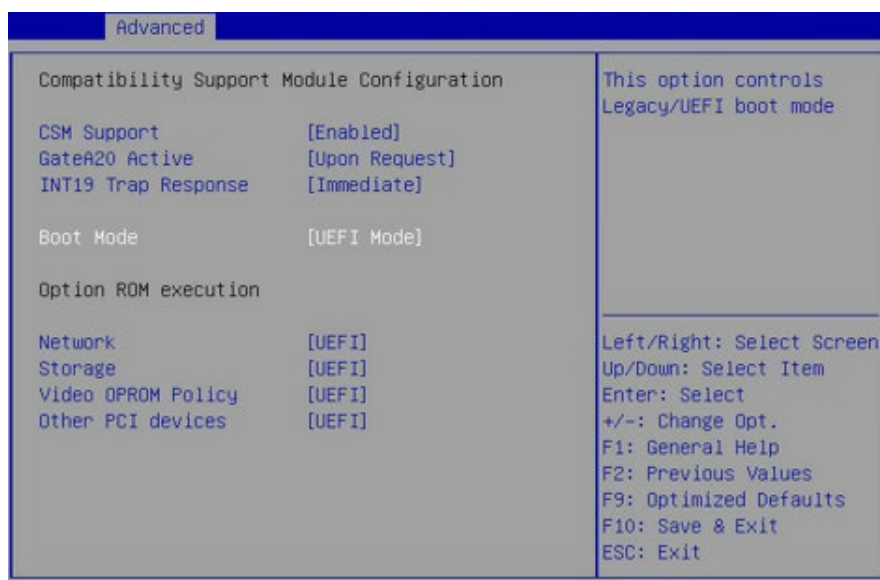

Figure 8-2

8.1.3 View System Information

Login to the BIOS Setup interface, and the Main menu displays the current system information, including BIOS/BMC/ME version, CPU/PCH SKU/RC version, memory and other information, as shown in the following figure.



Figure 8-3

8.1.4 View CPU Information

Login to the BIOS interface, select “Processor -> Processor Configuration -> Processor Information”, and press Enter to display the CPU detailed information, as shown in the following figure.

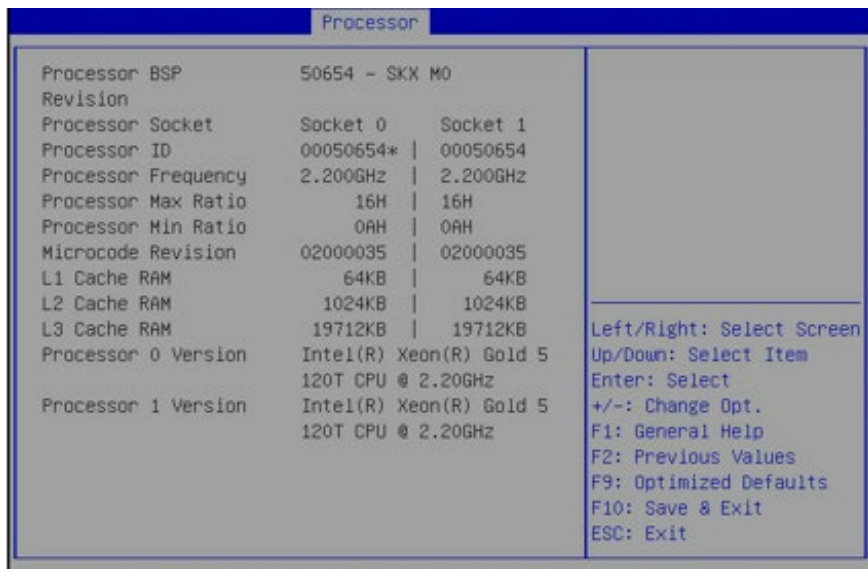

Figure 8-4

8.1.5 View Memory Information

Login to the BIOS interface, select “Processor -> Memory Configuration -> Memory Topology”, and press Enter to display the manufacturer, speed, capacity and other

information of the memories in position, as shown in the following figure.

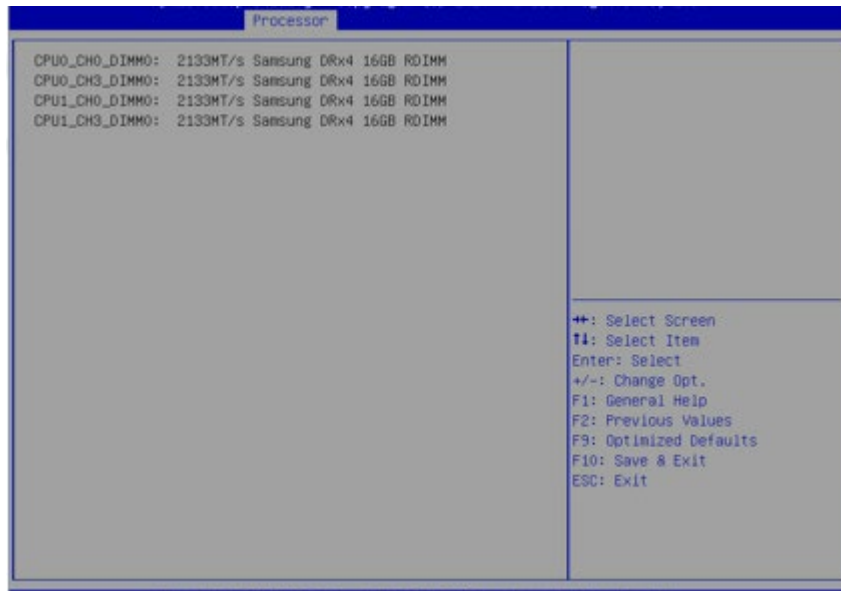

Figure 8-5

8.1.6 View HDD Information and RAID Configuration

8.1.6.1 View HDD Information

Login to the BIOS interface, select “Chipset -> PCH SATA Configuration/PCH sSATA Configuration”, and press Enter to display the HDD information of the current onboard SATA ports or sSATA ports, as shown in the following figures.

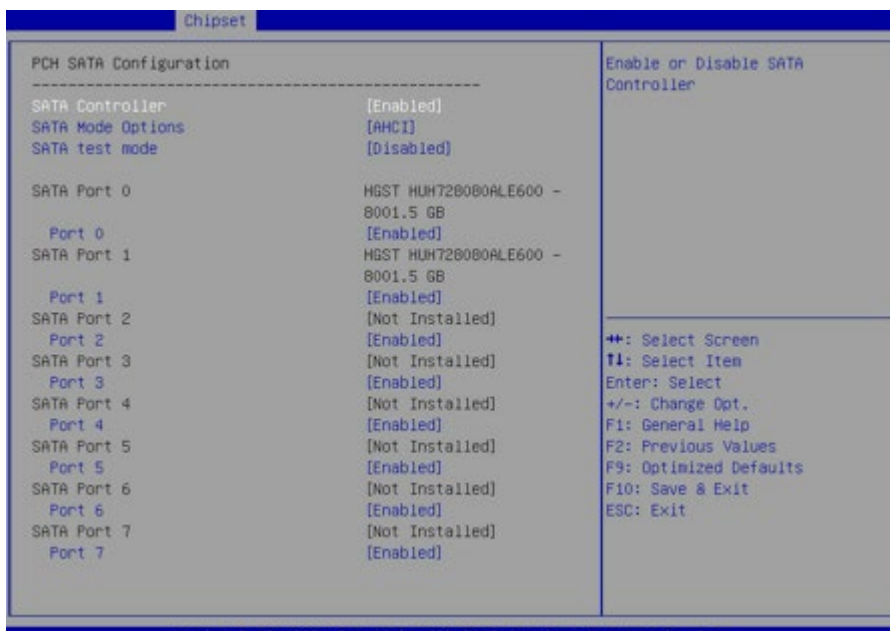

Figure 8-6

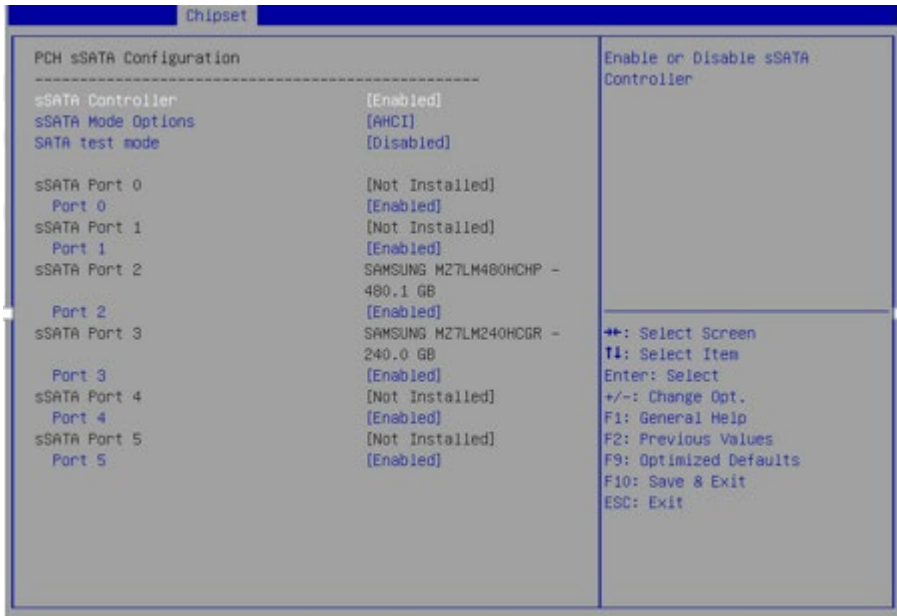

Figure 8-7

8.1.6.2 RAID Mode Settings

1. Set the SATA Mode Option to [RAID], press F10 to save the setting, and the system reboots.
2. When Boot Mode is set to UEFI mode, in the BIOS Setup Advanced interface, there will be the Intel(R) RSTe SATA Controller menu, as shown in the following figure.

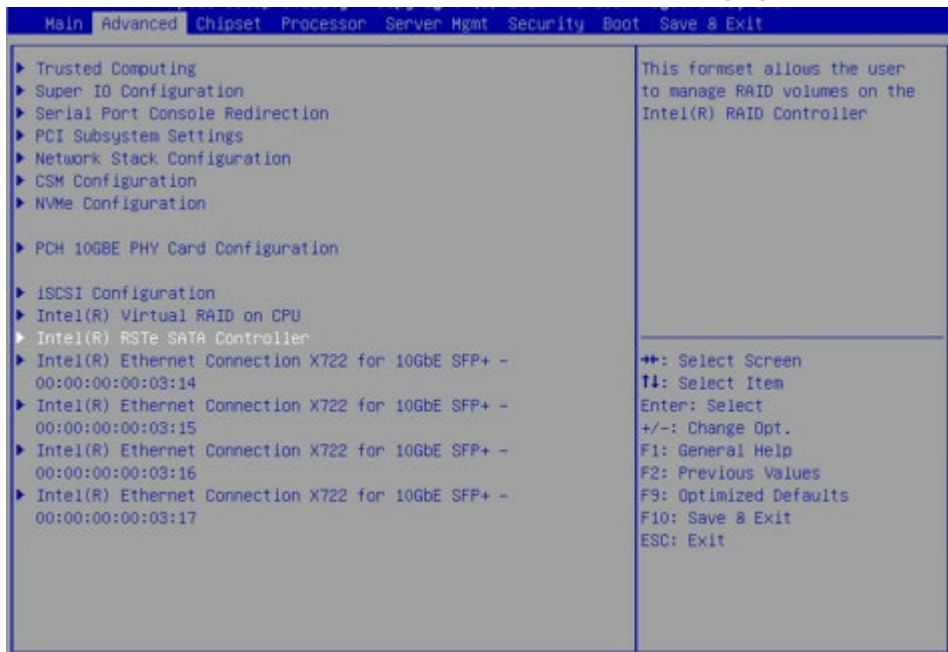

Figure 8-8

2.1 Press Enter, the executable operation and the current disk information will be displayed, as shown in the following figure.

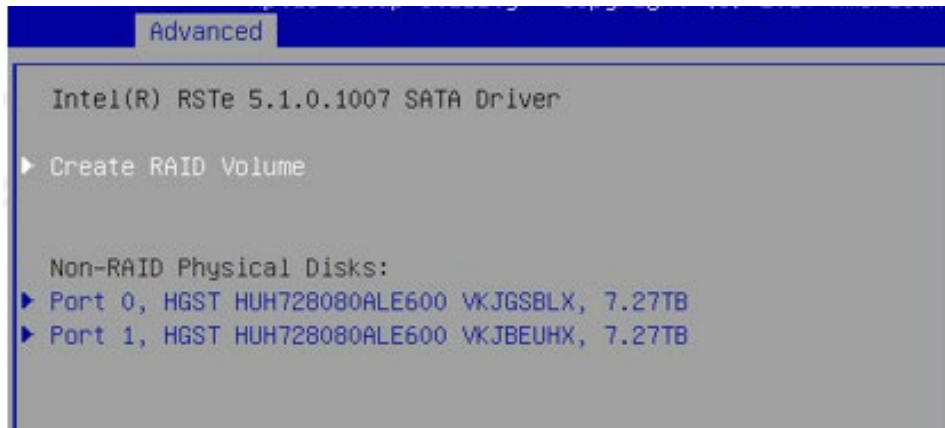

Figure 8-9

2.2 Create RAID volume. Select Create RAID Volume option, and press Enter, as shown in the following figure.

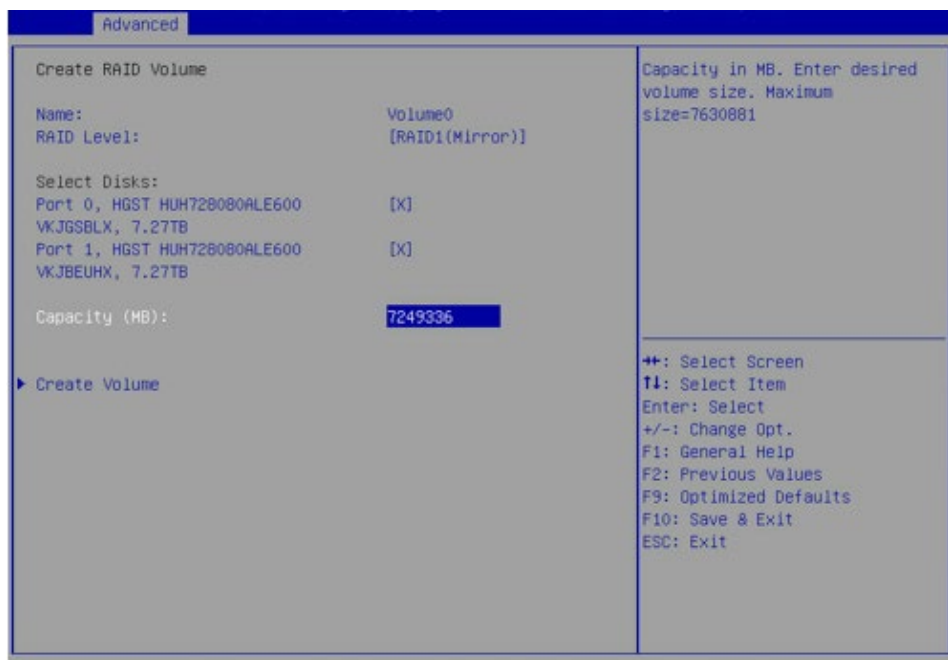

Figure 8-10

Table 8-2 Create RAID Menu Instruction Table

Interface Parameters	Function Description
Name	Please enter a volume name less than 16 characters without containing any special characters.
RAID Level	Please select the RAID volume level. If no volume has been created at present, there are four volume levels of RAID0 (Stripe), RAID1 (Mirror), RAID10 (RAID0+1) and RAID5 (Parity) for selection. Please select the volume level according to actual requirements. RAID0: This RAID volume is allowed to be made on 2 or above disks. RAID1: This RAID volume is allowed to be made on 2 disks. RAID10: This RAID volume is allowed to be made on 4 disks, which is only available when disk quantity is 4 or above. RAID5 (Parity): This RAID volume is allowed to be made on 3 or above disks.
Select Disks	Select disks to make RAID volume, press Enter, select X, and then press Enter to return to Create RAID Volume interface.
Strip Size	Please select the strip size, only RAID0 and RAID5 volumes could enable this option.
Capacity	Set the volume capacity, and the maximum capacity is shown in the Help information on the right side.
Create Volume	After finishing the above settings, select this option to create RAID volume.

2.3 Delete RAID volume. Select a created RAID Volume, press Enter. Select “Delete”, there will be a prompt. To delete the volume, select “Yes” and press Enter; to cancel the deletion, select “No” and press Enter.

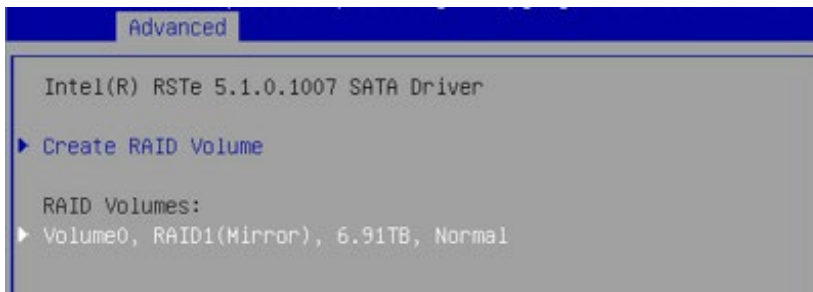

Figure 8-11

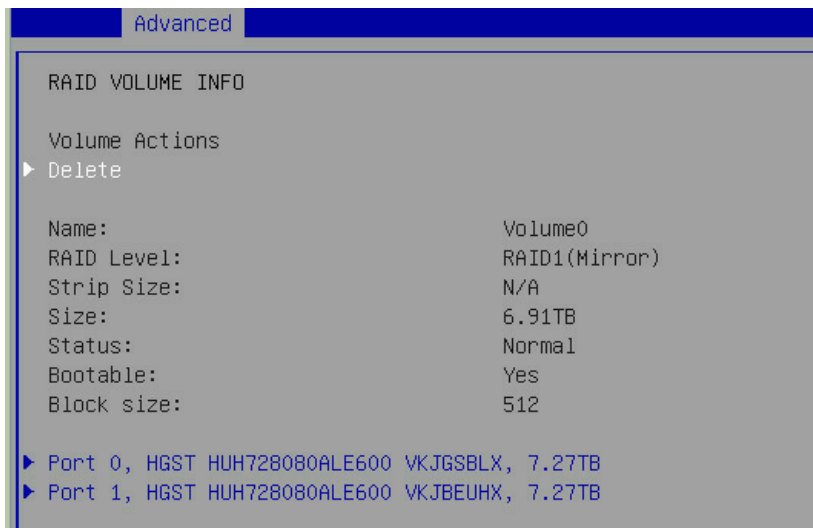

Figure 8-12

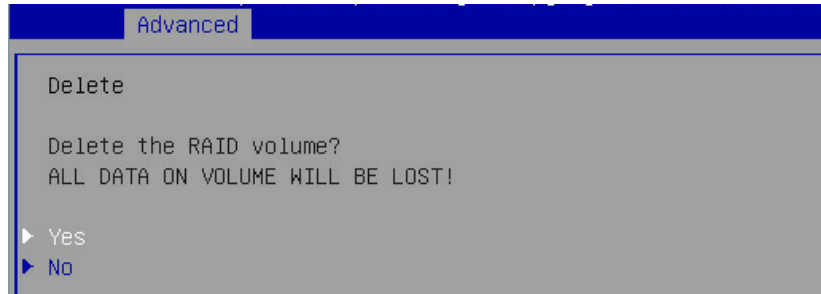

Figure 8-13

3. When Boot Mode is set to Legacy, a prompt “Press <CTRL-I> to enter Configuration Utility...” will appear on the screen during system booting. Press [Ctrl] and [I] keys at the same time to enter SATA RAID configuration, as shown in the following figure.



Figure 8-14

3.1 After entering SATA RAID configuration interface, it will display the main menu list, the information (disk ID, disk type, disk capacity, volume member or not) of disks connected to SATA controller, and the existed RAID volumes information (including volume ID, name, RAID level, capacity, status, bootable or not). There are 5 executable menus in the SATA RAID configuration interface, as shown in the following figure.

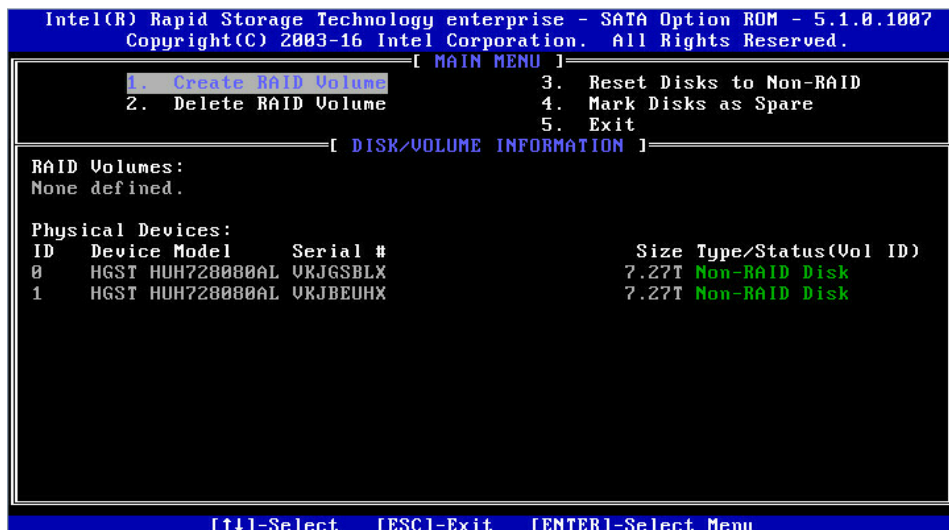

Figure 8-15

Table 8-3 Key Instruction Table

Key	Description
↑↓	Used to move cursor in different menus or to change values of menu options
TAB	To select the next menu option
Enter	To select a menu
Esc	To exit menu or return to previous menu from sub-menu

Table 8-4 Menu Instruction Table

Create RAID Volume	To create an RAID volume
Delete RAID Volume	To delete an existed RAID volume
Reset Disks to Non-RAID	To reset disks in RAID volume, and to restore them to non-RAID status
Mask Disk as Spare	To mask the disks as spare disks. The data will be cleared, and these disks can not be selected during RAID setting. It can be restored through the Reset Disks to Non-RAID menu.
Exit	To exit SATA Host RAID configuration interface

3.2 Create RAID Volume menu. After entering SATA RAID configuration interface, you could use up and down arrow keys to select this menu, and then press Enter to enter the Create RAID Volume menu, or directly input the number before the menu to enter the Create RAID Volume menu. For other menu operations that are similar, it will not be repeated here.

A Create RAID Volume instance is shown in the following figure:

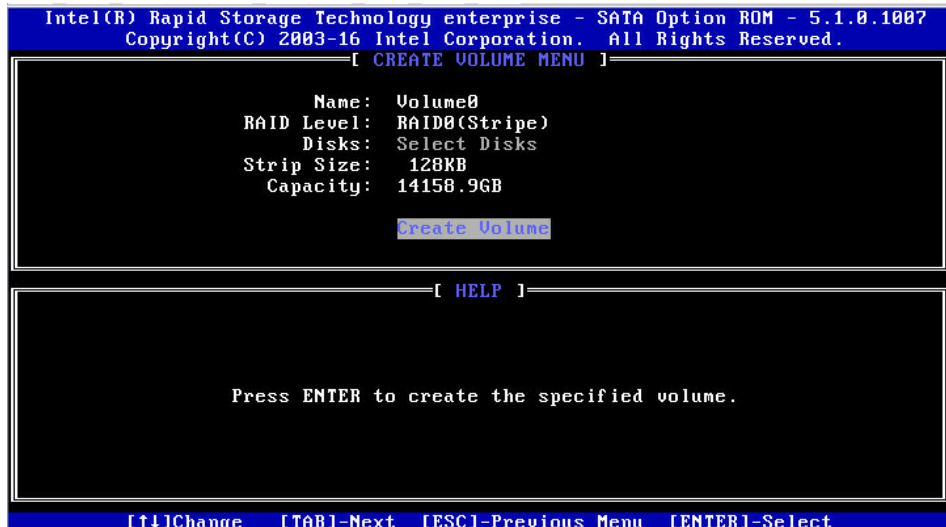

Figure 8-16

Table 8-5 Create RAID Menu Instruction Table

Interface Parameters	Function Description
Name	Please enter a volume label name less than 16 characters without containing any special characters.
RAID Level	Please select RAID volume level. If no volume has been created at present, there are four volume levels of RAID0 (Stripe), RAID1 (Mirror), RAID10 (RAID0+1) and RAID5 (Parity) for selection. Please select volume level according to actual requirements. RAID0: This RAID volume is allowed to be made on 2 or above disks. RAID1: This RAID volume is allowed to be made on 2 disks. RAID10: This RAID volume is allowed to be made on 4 disks, which is only available when disk quantity is 4 or above. RAID5 (Parity): This RAID volume is allowed to be made on 3 or above disks.
Select Disks	Select disks to make RAID volume, press Enter, select X, and then press Enter to return to Create RAID Volume interface.
Strip Size	Please select the strip size, only RAID0 and RAID5 volumes could enable this option.
Capacity	Set the volume capacity.

After completing the above settings, please select [Create Volume], and press Enter. The system will prompt “WARNING: ALL DATA ON THE SELECTED DISKS WILL BE LOST. Are you sure you want to create this volume? (Y/N)”. To create an RAID volume, please enter “Y”. A volume will be created, and all data on the selected disks will be lost. Otherwise, please enter “N”, to exit volume creation. Here we enter “Y” to create an RAID volume. After the creation is completed, return to MAIN MENU interface, the created RAID volume will be displayed.

3.3 Delete RAID Volume menu. After entering Delete RAID Volume menu, press [DEL] to delete the selected RAID volume, and the system will prompt “ALL DATA IN THE VOLUME WILL BE LOST! Are you sure you want to delete “Volume0*”? (Y/N)”. To delete this RAID volume, please enter “Y”, to cancel the deletion, please enter “N”.

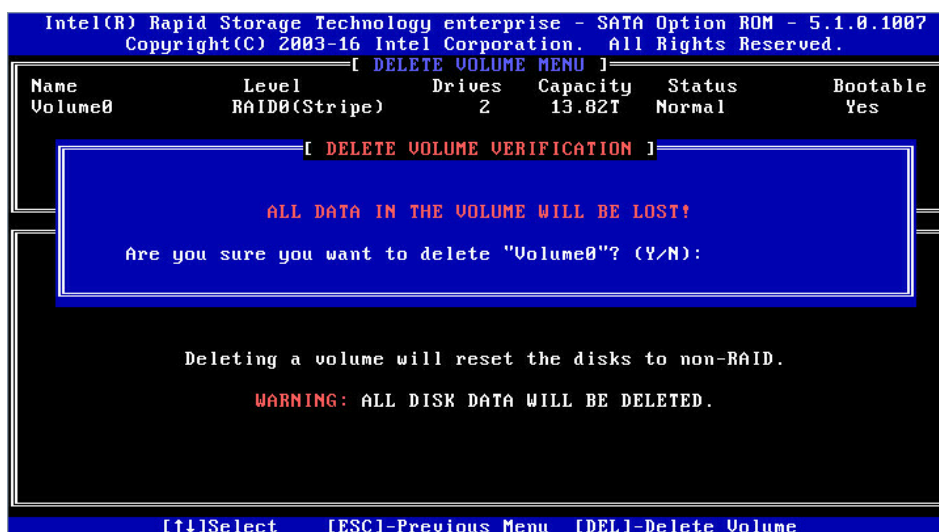

Figure 8-17

3.4 Reset Disks to Non-RAID menu. After entering Reset Disks to Non-RAID menu, system

will display all disks in RAID volume. Please use the space key to select the disk to reset according to the actual demand, and then press Enter to reset the disk. The system will prompt “Are you sure you want to reset RAID data on selected disks? (Y/N)” again, enter “Y” or “N” according to the prompt. It is to be noted that all data on this disk will be lost after reset. Meanwhile, this disk will not belong to RAID volume any more.

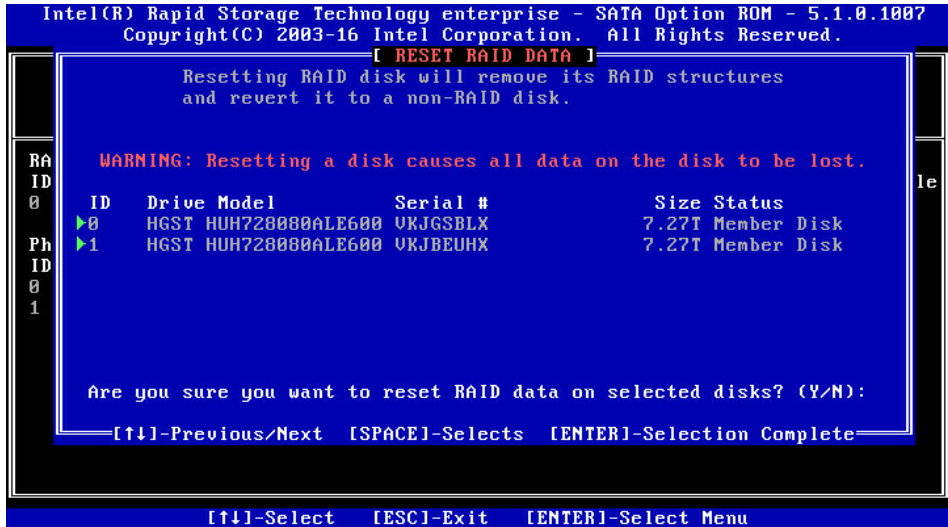

Figure 8-18

3.5 Mask Disk as Spare menu. After entering Mask Disk as Spare menu, system will display the disks not in RAID volume. Please use the space key to select the disks according to the actual demand, and then press Enter. The system will prompt “Are you sure you want to mask selected disks as Spare? (Y/N)”, enter “Y” or “N” according to the prompt. It is to be noted that all data on this disk will be lost as the spare disk.

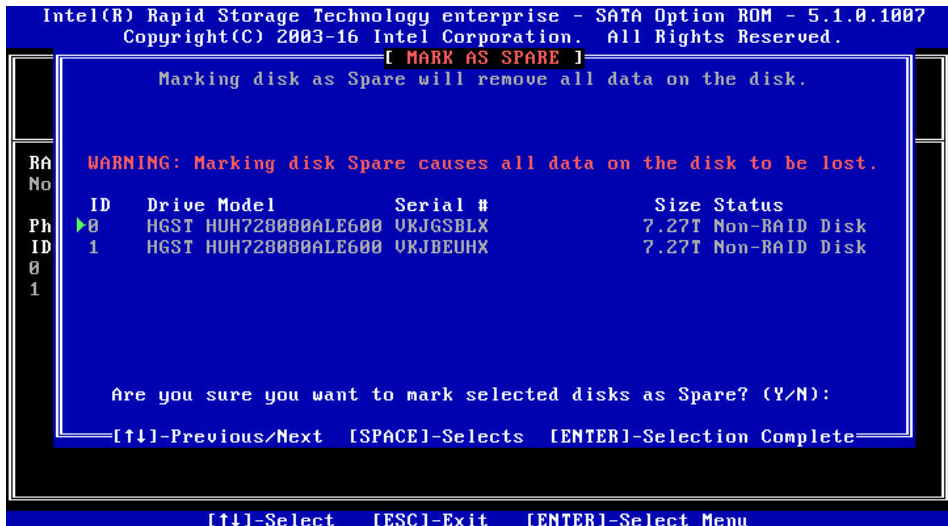

Figure 8-19

3.6 Exit menu. Select Exit menu through up and down keys, or press ESC to exit SATA RAID configuration interface, as shown in the following figure. The system will prompt “Are you sure you want to exit? (Y/N)”, enter “Y” to exit, or enter “N” to cancel the exit operation.

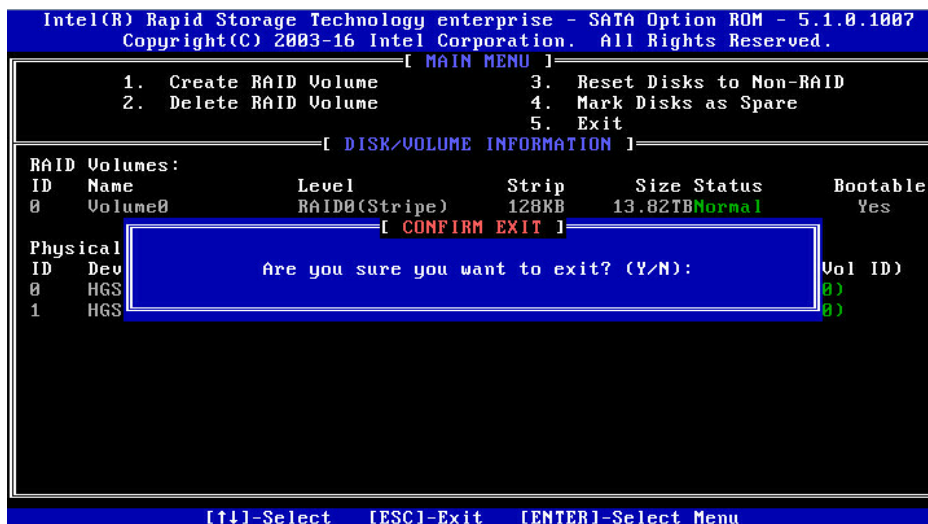

Figure 8-20

8.1.7 View and Set BMC Network Parameters

8.1.7.1 View BMC Network Parameters

Login to the BIOS interface, select “Server Mgmt -> BMC Network Configuration -> BMC IPv4 Network Configuration/BMC IPv6 Network Configuration”. Press Enter to view the current configuration of BMC IPv4 and BMC IPv6 network, as shown in the following figures.

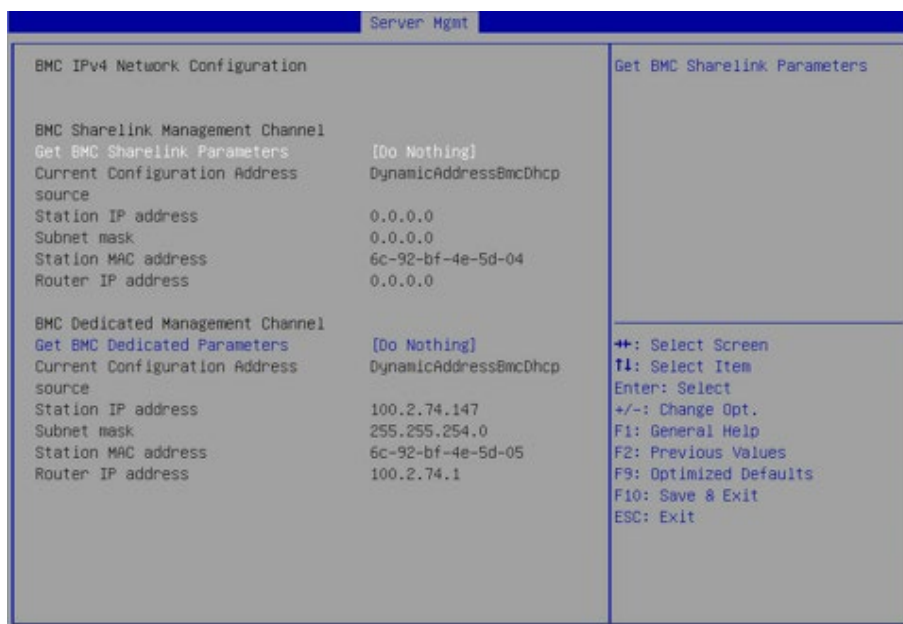

Figure 8-21

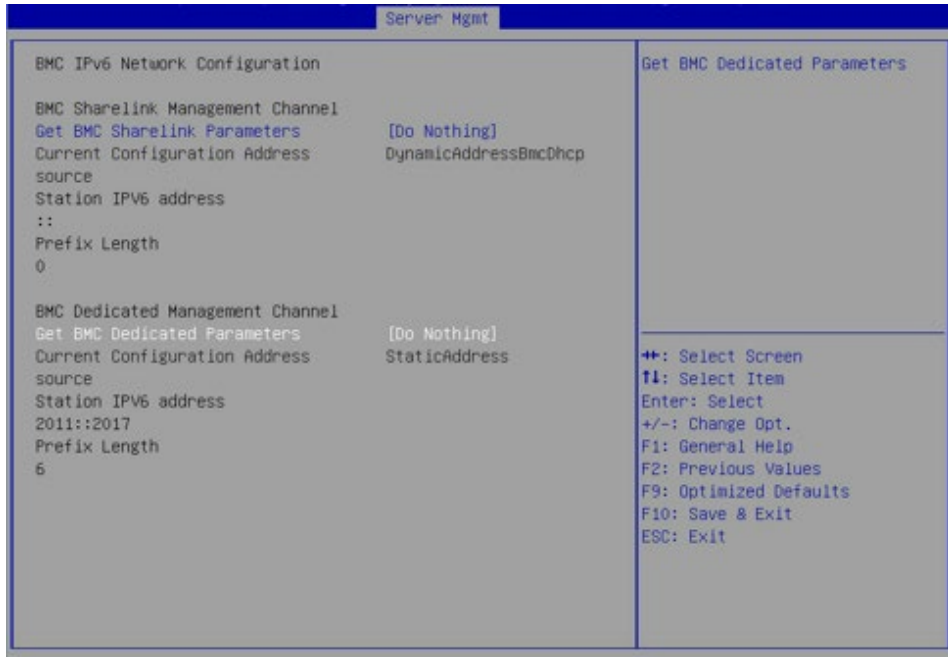

Figure 8-22

8.1.7.2 BMC Network Settings

Take BMC Sharelink port as an example to introduce the settings of BMC IPv4 network parameters, as shown in the following table.

Table 8-6 BMC Network Configuration Instruction Table

Interface Parameters	Function Description	Default Value
Get BMC Sharelink /Dedicated Parameters	Set the way to get BMC network parameters, options include: Do Nothing Auto Manual	Do Nothing
Configuration Address Source	Configure BMC network status parameters. When Get BMC Dedicated Parameters is set to [Manual], this option will be displayed. Options include: Unspecified Static DynamicBmcDhcp The static and dynamic settings take effect immediately.	Unspecified
Current Configuration Address	Display the current BMC network parameters configuration	----
Station IP address	BMC station IP address	----
Subnet mask	Subnet mask	----
Station MAC address	BMC station MAC address	----
Router IP address	BMC router IP address	----

8.1.7.3 Set Static BMC Network Parameters

Set the Configuration Address Source option to [Static]. If the setting succeeds, the system

will prompt “Set Static BMC IP Address Source Success!!”, as shown in the following figure.

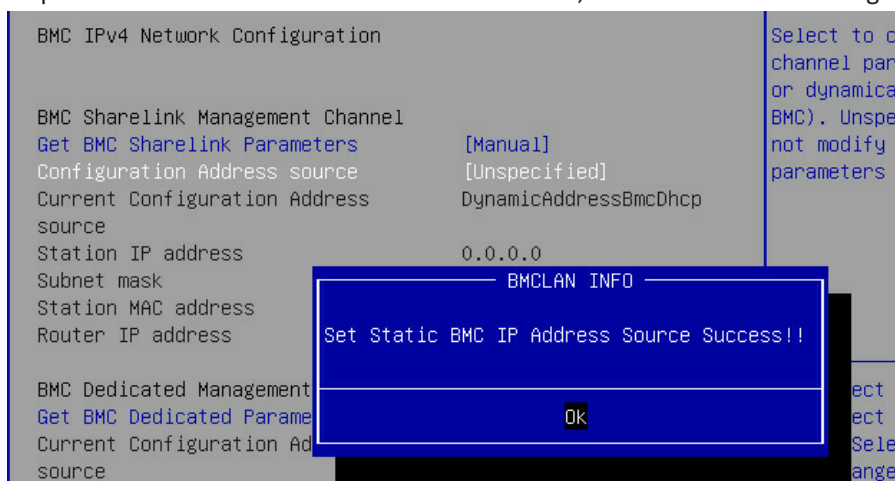

Figure 8-23

Select the Station IP Address option. Press Enter, the Station IP Address window pops up. Input the Static IP manually. After the setting is completed, press Enter to confirm, as shown in the following figures:

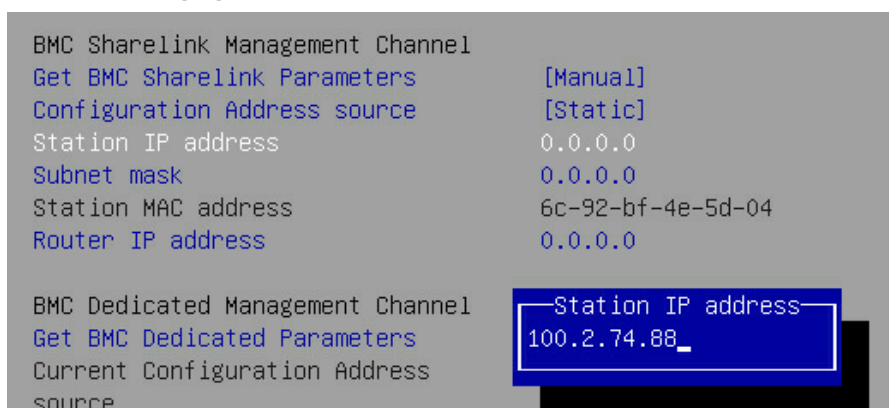

Figure 8-24

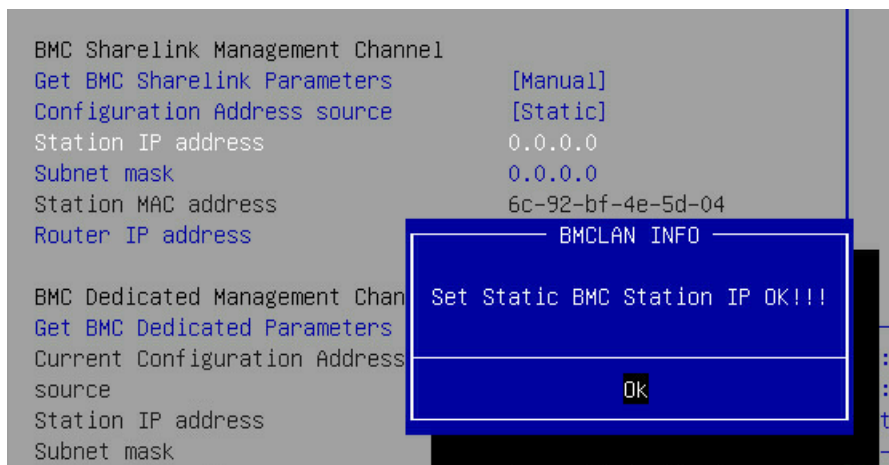

Figure 8-25

If the setting succeeds, the system prompts “Set Static BMC Station IP OK!!!” Press Enter to confirm, and the IP will take effect immediately.

If the setting fails, the system prompts “Set Static BMC Station IP Fail!!!”

If the IP does not change, the system prompts “Static BMC Station IP Not Change!!!”

If the input IP is invalid, the system prompts “Invalid Station IP Entered!!!”, and assign 0.0.0.0 to the IP address. The assignment only changes the IP address in BIOS Setup interface, and does not notify BMC to change the IP settings.

The prompts of Subnet mask and Router IP address settings are similar to those of Station IP address setting, there is no more detailed description here. As shown in the following figure, the BMC network parameters have taken effect, you can login to BMC Web interface to operate.

```

BMC Sharelink Management Channel
Get BMC Sharelink Parameters          [Manual]
Configuration Address source          [Static]
Station IP address                     100.2.74.88
Subnet mask                            255.255.254.0
Station MAC address                    6c-92-bf-4e-5d-04
Router IP address                       100.2.74.1
    
```

Figure 8-26

8.1.7.4 Set Dynamic BMC Network Parameters

Set the Configuration Address Source option to [DynamicBmcDhcp]. If the setting succeeds, the system will prompt “Set Dynamic BMC IP Address Source Success! Dynamic BMC Network Parameters are Getting Now, Please Wait a Moment!”, as shown in the following figure.

```

BMC Sharelink Management Channel
Get BMC Sharelink Parameters          [Manual]
Configuration Address source          [Static]
Station IP address                     100.2.74.88
Subnet mask                            255.255.254.0
Station MAC address                    6c-92-bf-4e-5d-04
Router IP address                       100.2.74.1

BMC Dedicated Management
Get BMC Dedicated Parameters
Current Configuration Address source
Station IP address
Subnet mask
Station MAC address
Router IP address
    
```

BMCLAN INFO

Set Dynamic BMC IP Address Source Success!
Dynamic BMC Network Parameters are Getting
Now, Please Wait a Moment!

OK

Figure 8-27

After pressing Enter to confirm, the following interface will stay for 30s, please wait patiently.

```

BMC IPv4 Network Configuration

BMC Sharelink Management Channel
Get BMC Sharelink Parameters      [Manual]
Configuration Address source      [Static]
Station IP address                100.2.74.88
Subnet mask                       255.255.254.0
Station MAC address              6c-92-bf-4e-5d-04
Router IP address

BMC Dedicated Management Channel [U]
Get BMC Dedicated Parameter      [S]
Current Configuration Address     [D]
source
Station IP address
Subnet mask
  
```

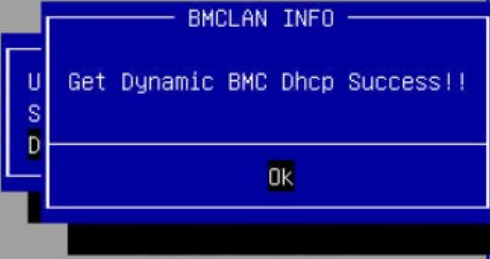

Figure 8-28

After the dynamic network takes effect, the system will prompt “Get Dynamic BMC Dhcp Success!!”, and the interface will be shown as the following figure.

```

BMC Sharelink Management Channel
Get BMC Sharelink Parameters      [Manual]
Configuration Address source      [DynamicBmcDhcp]
Current Configuration Address     DynamicAddressBmcDhcp
source
Station IP address                100.2.74.24
Subnet mask                       255.255.254.0
Station MAC address              6c-92-bf-4e-5d-04
Router IP address                100.2.74.1
  
```

Figure 8-29



Note:

Please make sure that the BMC management port is connected to the network when you use the Manual setting options.

The options that take effect immediately in the BIOS Setup interface are implemented by calling the Callback function. Callback functions are only called when the options in the BIOS Setup interface are changed. Otherwise, the function will not take effect. For example, if you want to automatically get BMC parameters again, you need to set Get BMC Sharelink Parameters to [Do nothing] or [Manual], then set to [Auto], the function will take effect.

The settings of BMC IPv6 network parameters are similar to this, which will be omitted here.

8.2 BIOS Parameter Description

8.2.1 Main

Main interface displays the basic information of BIOS system, including BIOS/BMC/ME version, CPU type, total memory capacity and system time.

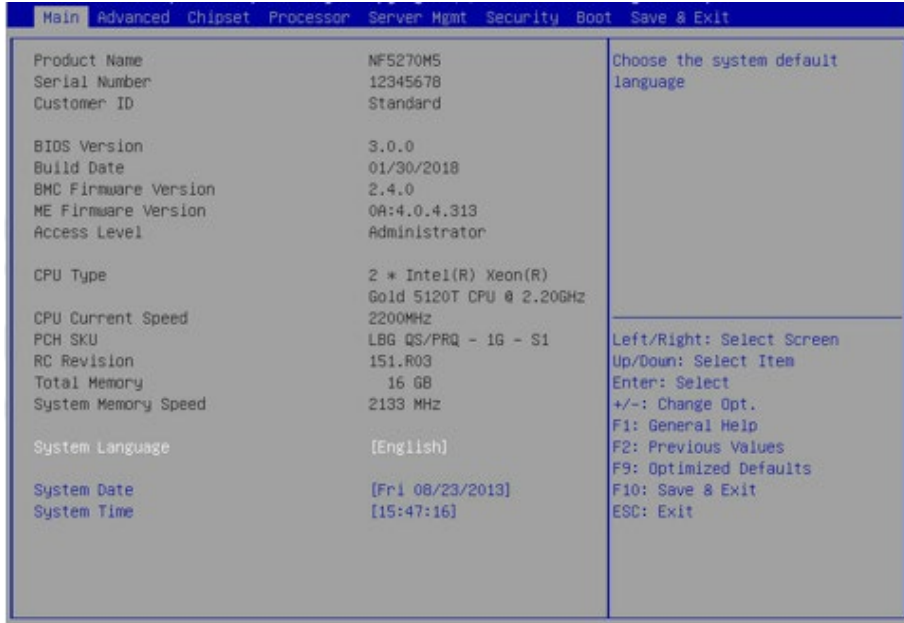

Figure 8-30

Table 8-7 Main Interface Instruction Table

Interface Parameters	Function Description
Product Name	Product name
Serial Number	Serial number
Customer ID	Customer ID
BIOS Version	BIOS version
Build Date	Build date
BMC Firmware Version	BMC FW version
ME Firmware Version	ME FW version
Access Level	Current access level
CPU Information	Display the current CPU's type, PCH SKU, RC version information.
Memory Information	Display the current total memory capacity and frequency information.
System Date (Day mm/dd/yyyy)	Display and set system date. Use [Tab] or [Enter] key to switch between system date and time, directly input the value or use +/- keys to change the value (Press + key, the value increases by 1, and press - key, the value decreases by 1).
System Time (hh/mm/ss)	Display and set system time. Use [Tab] or [Enter] key to switch between system date and time, directly input the value or use +/- keys to change the value (Press + key, the value increases by 1, and press - key, the value decreases by 1).

8.2.2 Advanced

Advanced interface includes the BIOS system parameters and related function settings, such as ACPI, serial port, PCI subsystem, CSM, USB, onboard NIC and so on.

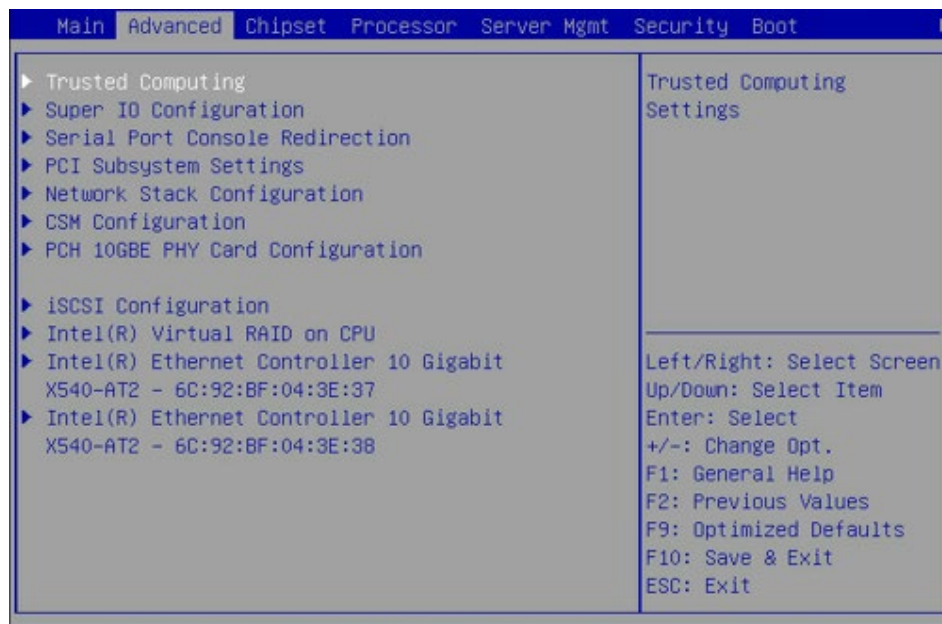

Figure 8-31

Table 8-8 Advanced Interface Instruction Table

Interface Parameters	Function Description
Trusted Computing	Trusted computing configuration
Super IO Configuration	AST2400 I/O chip parameter configuration
Serial Port Console Redirection	Serial port console redirection settings
PCI Subsystem Settings	PCI subsystem settings
Network Stack Configuration	Network stack configuration
CSM Configuration	CSM configuration
NVMe Configuration	NVMeconfiguration
PCH 10GBE PHY Card Configuration	PCH 10GBE PHY card configuration
iSCSI Configuration	iSCSI configuration
Intel(R) Virtual RAID on CPU	Intel NVMe virtual RAID configuration
Intel® Ethernet Connection X722 for 10GbE SFP+XX:XX:XX:XX:XX:XX	Intel 10G NIC UEFI OPROM configuration

8.2.2.1 Trusted Computing

Trusted Computing interface is used to enable or disable BIOS support for security device.

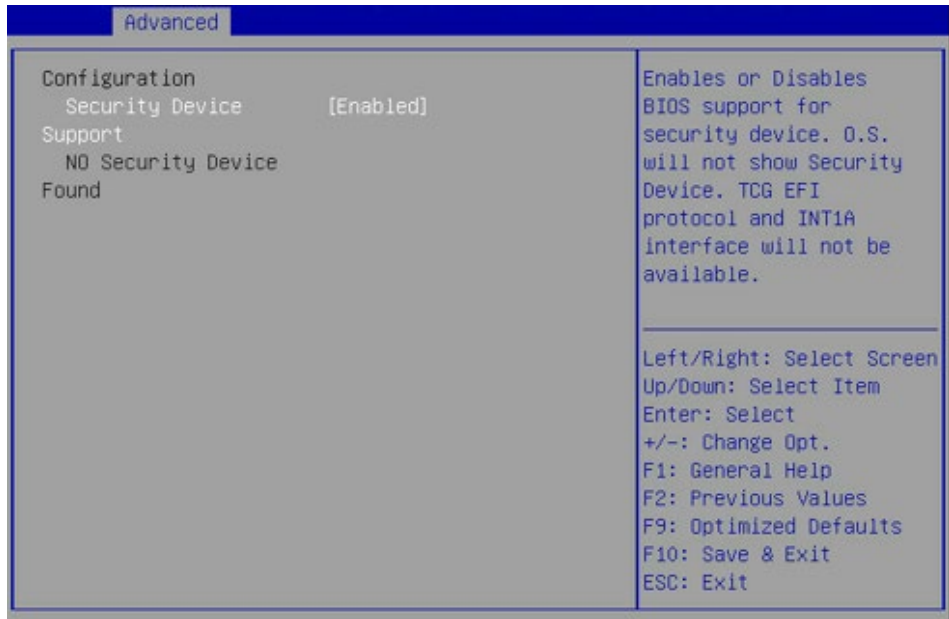

Figure 8-32

Table 8-9 Trusted Computing Interface Instruction Table

Interface Parameters	Function Description	Default Value
Security Device Support	Security device support settings. Options include: Enabled Disabled BIOS supports TPM TCG version 1.2/2.0. BIOS supports TPM module through TPM software binding, when the verification of software binding fails, BIOS will record the error to SEL.	Enabled
No Security Device Found	Display the status of security device. There is no information displayed at present, to enable this function, it needs to install TPM chip.	----

8.2.2.2 Super IO Configuration

Super IO Configuration interface is used to set the options related with I/O chip.

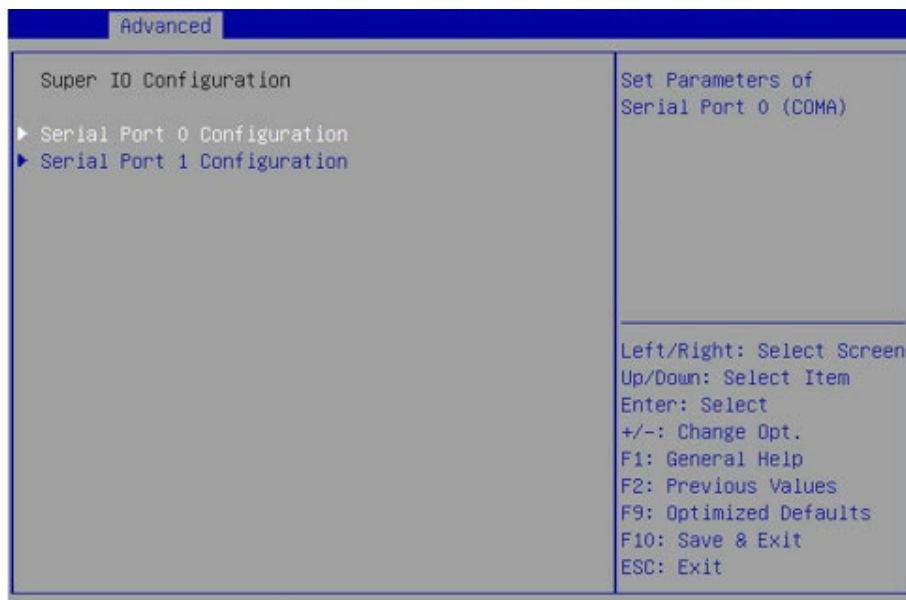

Figure 8-33

Table 8-10 Super IO Configuration Interface Instruction Table

Interface Parameters	Function Description
Serial Port 0 Configuration	Serial port 0 configuration, the configuration interface provides this serial port's on-off control and resource allocation control. Users can manually adjust the IO PORT and IRQ number that COM PORT uses.
Serial Port 1 Configuration	Serial port 1 configuration (virtual serial port)

8.2.2.2.1 Serial Port 0 Configuration

Serial Port 0 Configuration interface is used to set the options related with serial port 0.



Figure 8-34

Table 8-11 Serial Port 0 Configuration Interface Instruction Table

Interface Parameters	Function Description	Default Value
Serial Port	Serial port 0 on-off settings. Options include: Enabled Disabled	Enabled
Change Settings	Select the optimal setting according to the demand. Options include: Auto IO=3F8h; IRQ=4; IO=3F8h; IRQ=3, 4, 5, 6, 7, 9, 10, 11, 12; IO=3E8h; IRQ=3, 4, 5, 6, 7, 9, 10, 11, 12; IO=2E8h; IRQ=3, 4, 5, 6, 7, 9, 10, 11, 12;	Auto

8.2.2.3 Serial Port Console Redirection

Serial Port Console Redirection interface is used to set the options related with the serial port redirection.

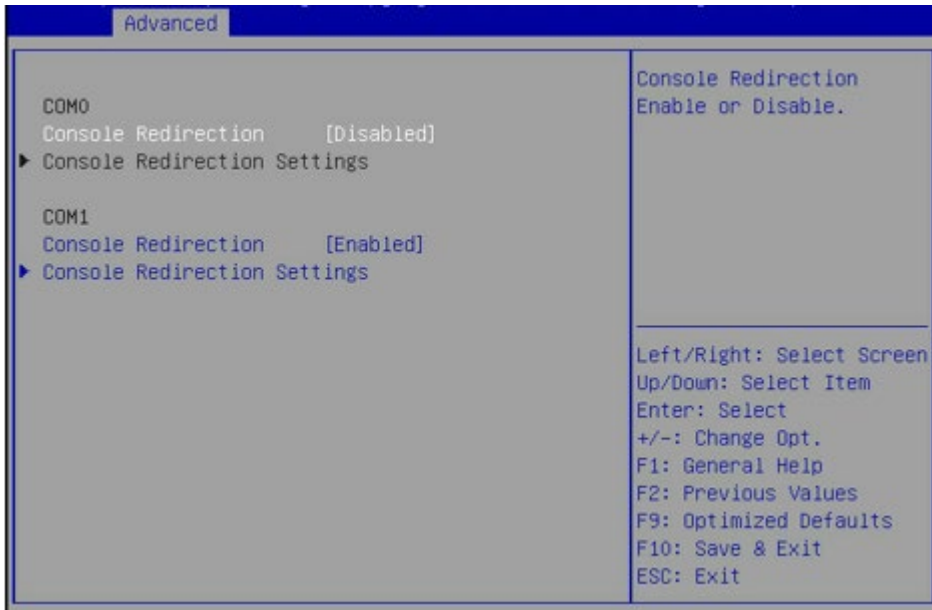

Figure 8-35

Table 8-12 Serial Port Console Redirection Interface Instruction Table

Interface Parameters	Function Description	Default Value
Console Redirection	Serial port console redirection on-off settings. Options include: Enabled Disabled	Disabled
Console Redirection Settings	Serial port console redirection parameter settings	----

8.2.2.4 Console Redirection Settings

When the Console Redirection is set to [Enabled], the Console Redirection Settings menu will be opened.

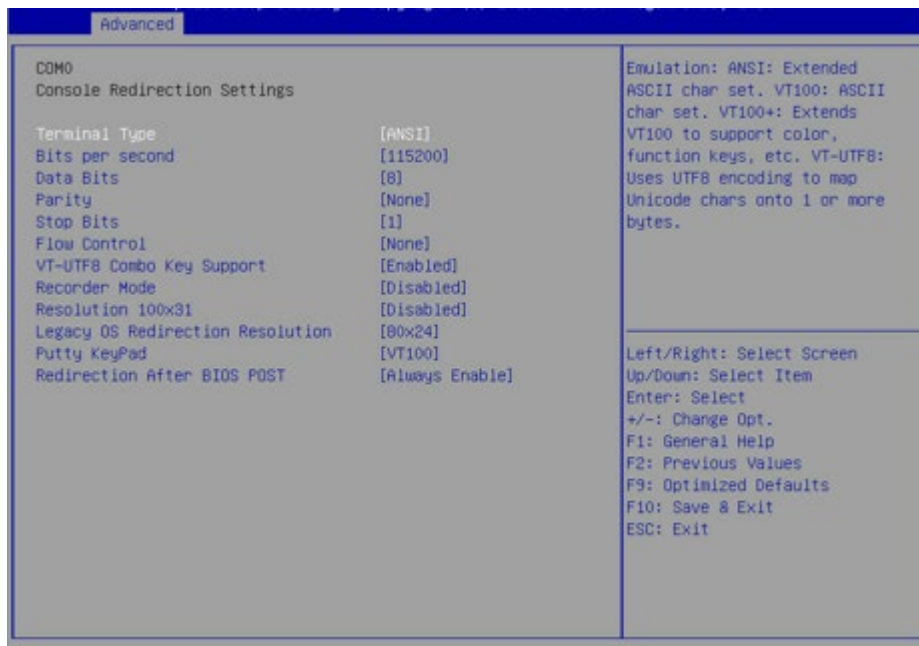

Figure 8-36

Table 8-13 Console Redirection Settings Interface Instruction Table

Interface Parameters	Function Description	Default Value
Terminal Type	Terminal type settings. Options include: VT100 VT100+ VT-UTF8 ANSI	ANSI
Bits per second	Baud rate settings. Options include: 9600 19200 38400 57600 115200	115200
Data Bits	Serial port data width settings. Options include: 7 8	8
Parity	Parity settings. Options include: None Even Odd Mark (odd-even check) Space (storage parity check)	None
Stop Bits	Stop bit settings. Options include: 1 2	1
Flow Control	Flow control settings. Options include: None Hardware RTS/CTS	None

VT-UTF8 Combo Key Support	VT-UTF8 combination key support on-off settings. Options include: Enabled Disabled	Enabled
Recorder Mode	Recorder mode on-off settings. Options include: Enabled Disabled	Disabled
Redirection 100×31	Expanded redirection resolution 100×31 on-off settings. Options include: Enabled Disabled	Disabled
Legacy OS Redirection Resolution	Legacy OS redirection resolution settings. Options include: 80×24 80×25	80×24
Putty KeyPad	Putty function keys and keyboard settings. Options include: VT100 LINUX XTERMR6 SCO ESCN VT400	VT100
Redirection After BIOS POST	Redirection after BIOS POST settings. Options include: Always Enable BootLoader	Always Enable

8.2.2.5 PCI Subsystem Settings

PCI Subsystem Settings interface is used to set the options related with PCI subsystem.

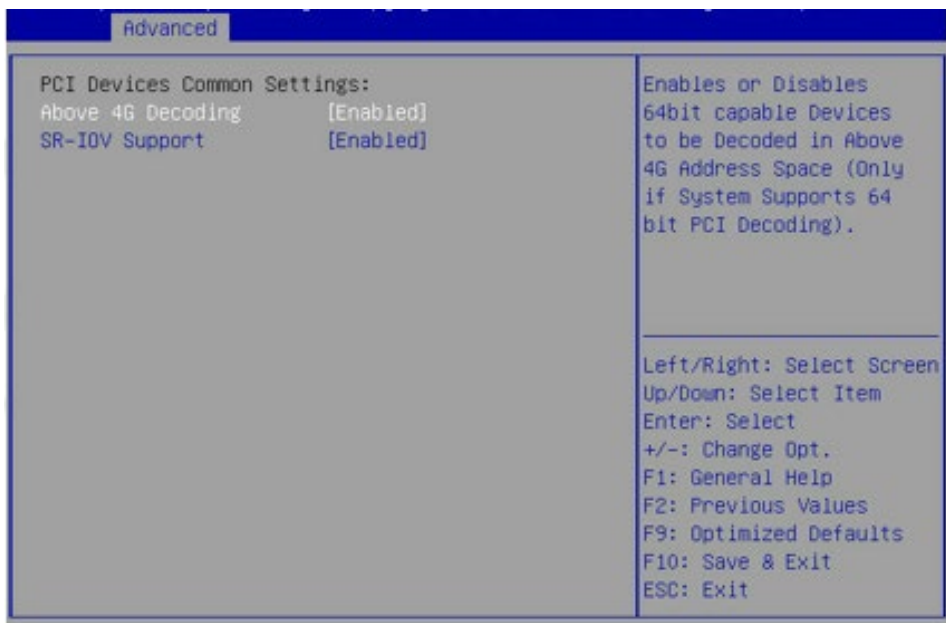

Figure 8-37

Table 8-14 PCI Subsystem Settings Interface Instruction Table

Interface Parameters	Function Description	Default Value
Above 4G Decoding	Above 4G memory access control on-off settings. Options include: Enabled Disabled	Enabled
SR-IOV Support	SR-IOV support on-off settings. Options include: Enabled Disabled	Enabled

8.2.2.6 Network Stack Configuration

Network Stack Configuration interface is used to set the options related with Network UEFI PXE.

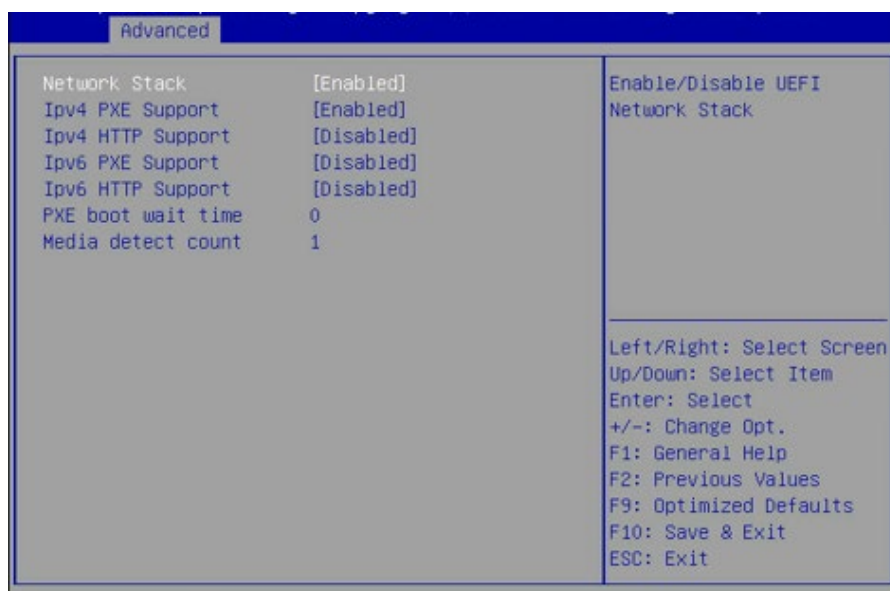

Figure 8-38

Table 8-15 Network Stack Configuration Interface Instruction Table

Interface Parameters	Function Description	Default Value
Network Stack	Network stack on-off settings. Options include: Enabled Disabled Only this option is enabled, the following options can be displayed and the functions can be set.	Enabled
Ipv4 PXE Support	UEFI Ipv4 PXE support on-off settings. Options include: Enabled Disabled	Enabled
Ipv4 HTTP Support	Ipv4 HTTP support on-off settings. Options include: Enabled Disabled	Disabled
Ipv6 PXE Support	UEFI Ipv6 PXE support on-off settings. Options include: Enabled Disabled	Disabled
Ipv6 HTTP Support	Ipv6 HTTP support on-off settings. Options include: Enabled Disabled	Disabled
PXE boot wait time	Set the wait time to cancel PXE boot after pressing ESC key, the setting range is 0~5.	0
Media detect count	Device detect count settings, the setting range is 1~50.	1

8.2.2.7 CSM Configuration

CSM Configuration interface is used to set the options related with the compatibility support module.

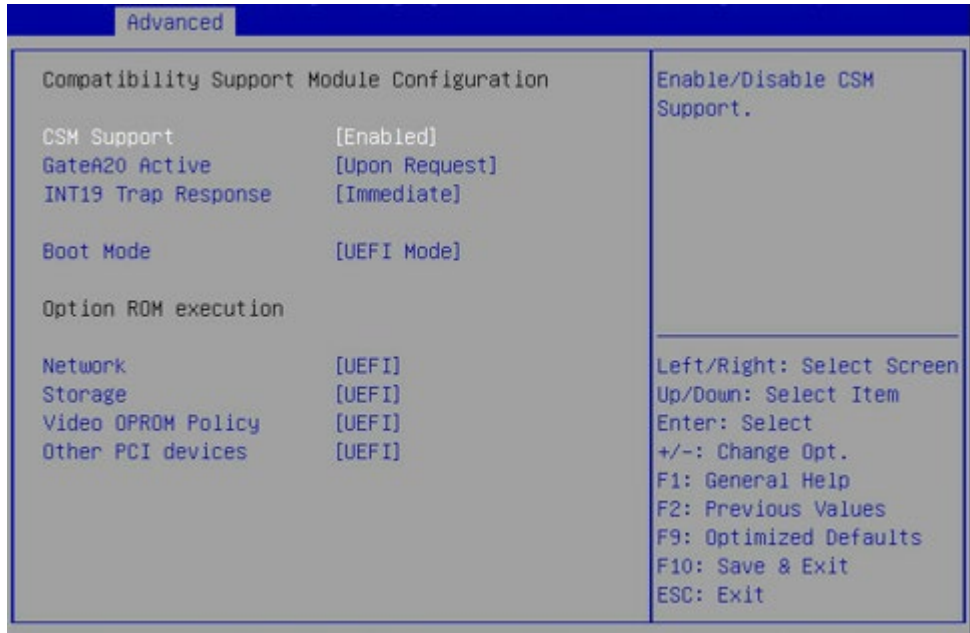

Figure 8-39

Table 8-16 CSM Configuration Interface Instruction Table

Interface Parameters	Function Description	Default Value
CSM Support	CSM support on-off settings. Options include: Enabled Disabled	Disabled
GateA20 Active	A20 line control mode settings. Options include: Upon Request Always A20 is an address line, which controls the system how to access the memory space larger than 1MB.	Upon Request
INT19 Trap Response	Interrupt/Capture signal response settings. Options include: Immediate Postponed	Immediate
Boot Mode	Boot mode settings. Options include: UEFI Mode Legacy Mode	UEFI Mode
Network	NIC Option ROM execution mode settings. Options include: Do not launch Legacy UEFI	UEFI
Storage	Storage device Option ROM execution mode settings. Options include: Do not launch Legacy UEFI	UEFI

Video OPROM Policy	Video device Option ROM execution mode settings. Options include: Do not launch Legacy UEFI	UEFI
Other PCI devices	Other PCI devices Option ROM execution mode settings. Options include: Do not launch Legacy UEFI	UEFI

8.2.3 Chipset

Chipset interface includes the information settings and runtime error logging settings of PCH SATA/sSATA, USB and ME devices.

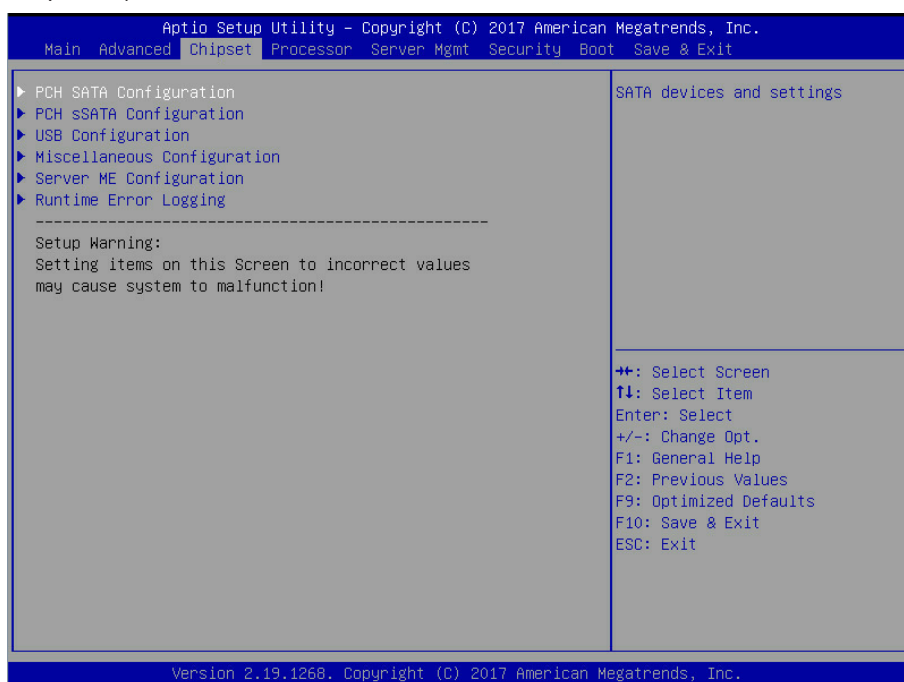

Figure 8-40

Table 8-17 Chipset Interface Instruction Table

Interface Parameters	Function Description
PCH SATA Configuration	PCH SATA configuration
PCH sSATA Configuration	PCH sSATA configuration
USB Configuration	USB configuration
Miscellaneous Configuration	Miscellaneous configuration
Server ME Configuration	Server ME configuration
Runtime Error Logging	Runtime error logging

8.2.3.1 PCH SATA Configuration/PCH sSATA Configuration

PCH sSATA Configuration and PCH SATA Configuration interfaces are used to set the options

related with the onboard sSATA/SATA ports. Take PCH SATA Configuration menu as an example, as shown in the following figure.

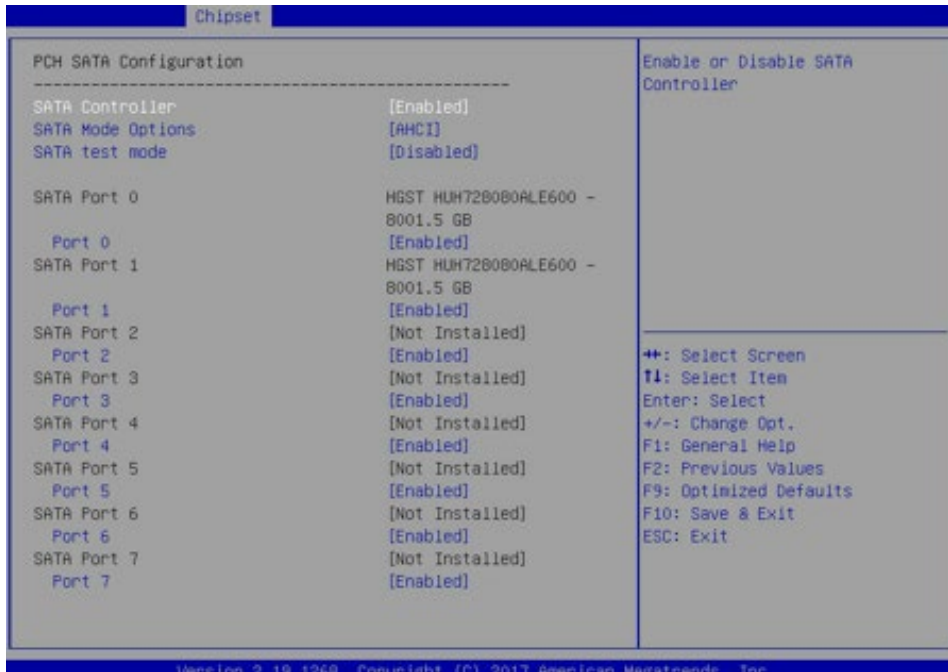

Figure 8-41

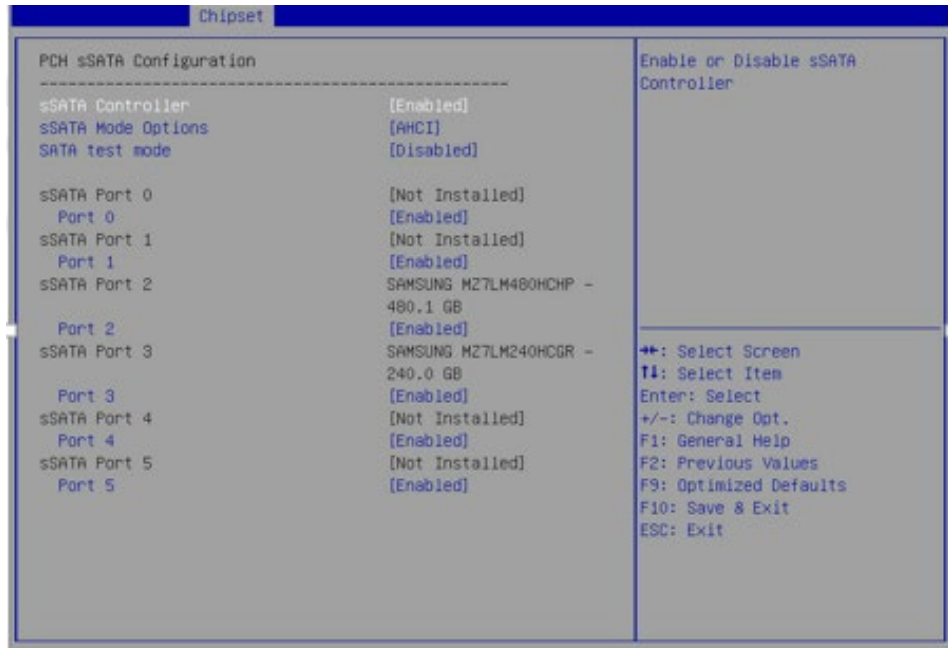

Figure 8-42

Table 8-18 PCH SATA Configuration Interface Instruction Table

Interface Parameters	Function Description	Default Value
SATA Controller	SATA controller on-off settings. Options include: Enabled Disabled	Enabled
SATA Mode Options	SATA mode settings. Options include: AHCI RAID	AHCI
SATA Port 0~7	SATA port 0~7 HDD information	----
Port 0~7	SATA port on-off settings. Options include: Enabled Disabled	Enabled

PCH sSATA Configuration Interface Instruction Table is omitted here.

8.2.3.2 USB Configuration

USB Configuration is used to set the options related with the onboard USB ports.

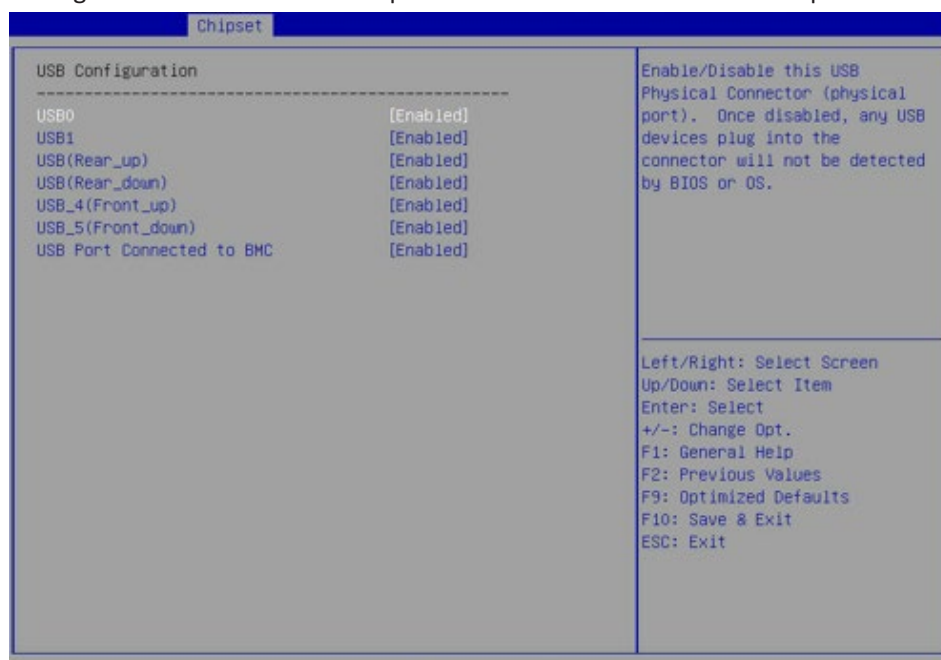

Figure 8-43

Table 8-19 USB Configuration Interface Instruction Table

Interface Parameters	Function Description	Default Value
USB N	Onboard USB port on-off settings. Options include: Enabled Disabled	Enabled

8.2.3.3 Miscellaneous Configuration

Miscellaneous Configuration interface is used to set some other common options.

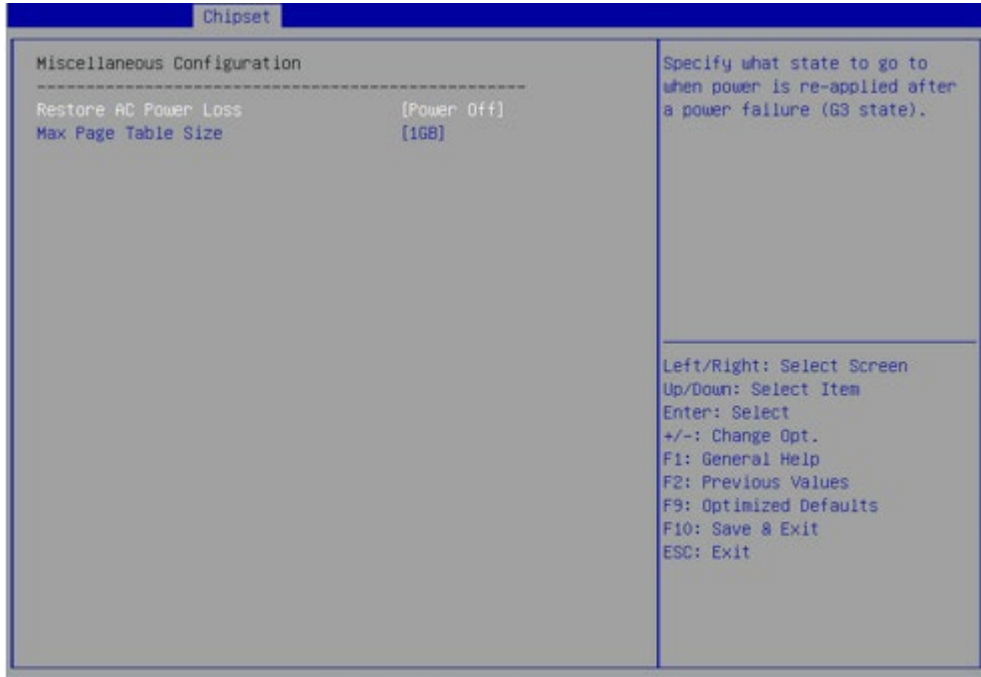

Figure 8-44

Table 8-20 Miscellaneous Configuration Interface Instruction Table

Interface Parameters	Function Description	Default Value
Restore AC Power Loss	Power state settings when restoring on AC power loss. Options include: Power OFF Last State Power ON	Power OFF
Max Page Table Size	The maximum page table size settings. Options include: 1GB 2MB For older OS, please select 2MB, otherwise, it may cause a problem.	1GB
VGA Priority	Onboard/OffboardVGA device priority settings. Options include: Onboard Device Offboard Device	Offboard Device

8.2.3.4 Server ME Configuration

Server ME Configuration interface is used to display and set the options related with server ME configuration.

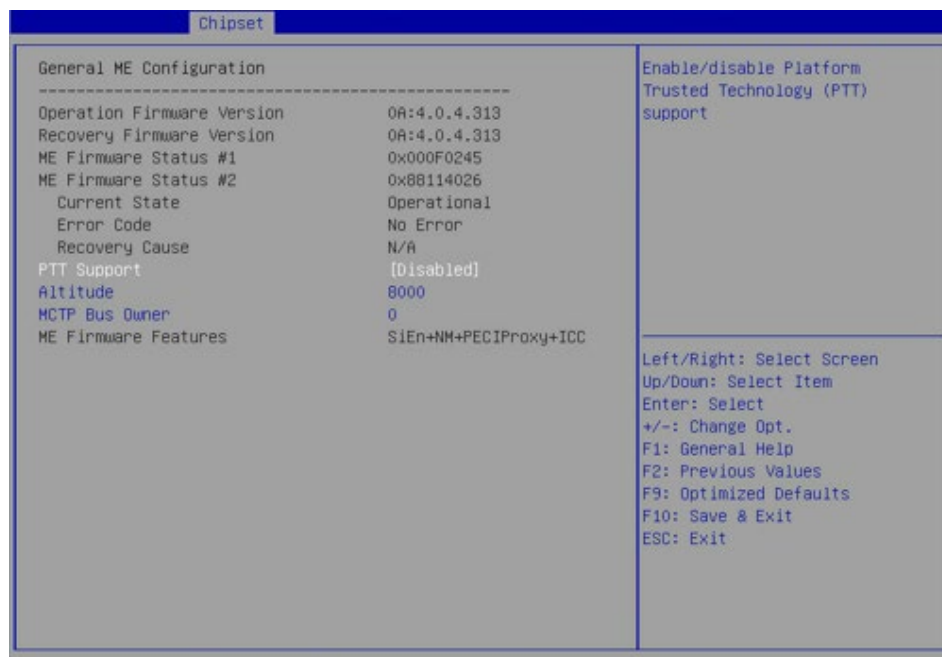

Figure 8-45

Table 8-21 Server ME Configuration Interface Instruction Table

Interface Parameters	Function Description	Default Value
Operational Firmware Version	Operational ME firmware version	----
Recovery Firmware Version	Recovery ME firmware version	----
ME Firmware Status #1	ME FW status value #1	----
ME Firmware Status #2	ME FW status value #2	----
Current State	Current state	----
Error code	ME FW error code	----
Recovery Cause	Recovery cause	N/A
PTT Support	PTT support on-off settings. Options include: Enabled Disabled	Disabled
Altitude	Altitude settings	8000
MCTP Bus Owner	MCTP bus owner is located in PCIe: [15:8] bus, [7:3] device, [2:0] function. If set to 0, it means disabled.	0
ME Firmware Features	ME FW features	----

8.2.3.5 Runtime Error Logging

Runtime Error Logging interface is used to set the runtime error logs.

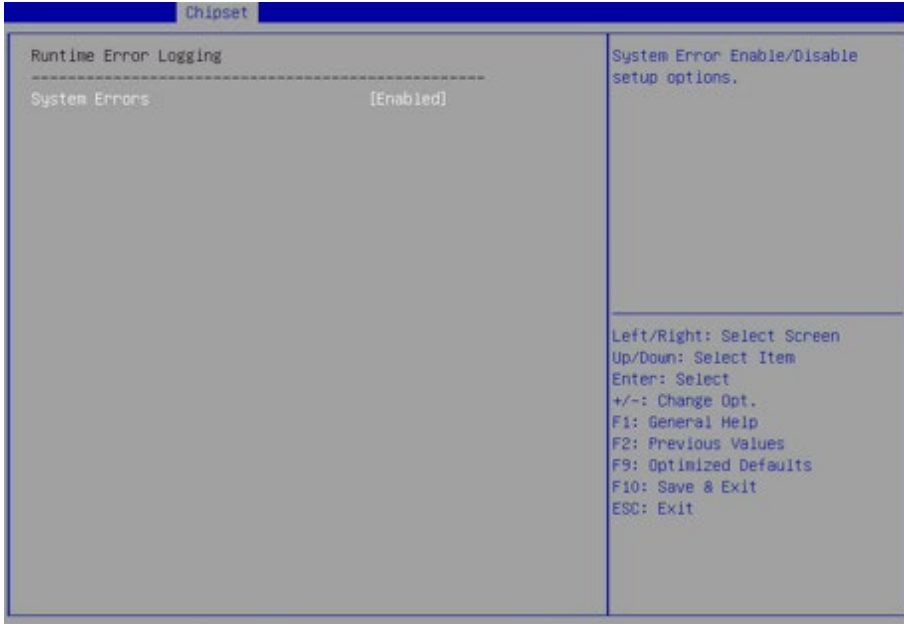

Figure 8-46

Table 8-22 Runtime Error Logging Interface Instruction Table

Interface Parameters	Function Description	Default Value
System Errors	System error log record settings. Options include: Enabled Disabled	Enabled

8.2.4 Processor

Processor interface is used to set the options related with the processor and memory.

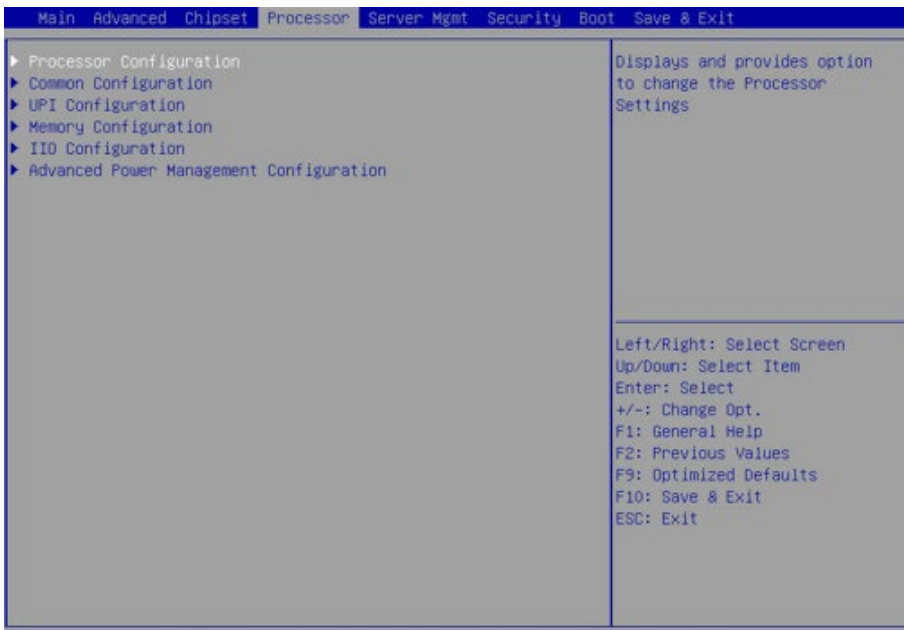

Figure 8-47

Table 8-23 Processor Interface Instruction Table

Interface Parameters	Function Description
Processor Configuration	Processor configuration
Common Configuration	Common configuration
UPI Configuration	UPI configuration
Memory Configuration	Memory configuration
IIO Configuration	IIO configuration
Advanced Power Management Configuration	Advanced power management configuration

8.2.4.1 Processor Configuration

Processor Configuration interface is used to set the options related with the processor.

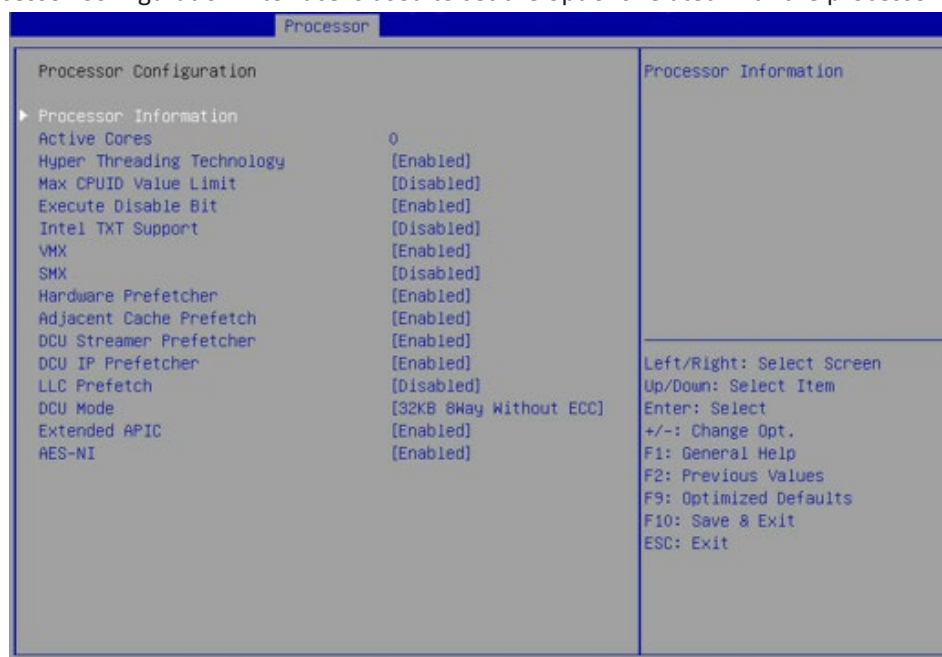

Figure 8-48

Table 8-24 Processor Configuration Interface Instruction Table

Interface Parameters	Function Description	Default Value
Processor Information	Processor information submenu, the processor's detailed information	----
Active Cores	CPU core settings. Input the number of CPU cores you want to enable. In the Help information, it will display the effective values you can set and the maximum number of physical cores according to the current CPU usage. The default value is 0, all cores enabled.	0
Hyper Threading Technology	Hyper threading technology on-off settings. Options include: Enabled Disabled	Enabled
Max CPUID Value Limit	The max CPUID value limit on-off settings. Enabled Disabled When the legacy OS boot does not support CPUID function, please enable this option.	Disabled

Execute Disable Bit	Execute disable bit on-off setting. Options include: Enabled Disabled	Enabled
Intel TXT Support	Intel trusted execution technology on-off settings. Options include: Enabled Disabled	Disabled
VMX	Intel virtual machine extensions technology on-off settings. Options include: Enabled Disabled	Enabled
SMX	Safe mode extension on-off settings. Options include: Enabled Disabled	Disabled
Hardware Prefetcher	Hardware prefetcher on-off settings. Options include: Enabled Disabled Before CPU processing instructions or data, it will prefetch these instructions or data from memory to L2 cache, to shorten the amount of time that reading memory takes, to help eliminate potential bottlenecks and to improve system performance.	Enabled
Adjacent Cache Prefetch	Adjacent cache prefetch on-off settings. Options include: Enabled Disabled If this function is enabled, during computer data reading, it will intelligently consider the adjacent data is needed as well, and it will prefetch these data during processing, to speed up the reading process.	Enabled
DCU Streamer Prefetcher	DCU streamer prefetcher on-off settings. Options include: Enabled Disabled This function can prefetch CPU data to shorten the data reading time.	Enabled
DCU IP Prefetcher	DCU IP prefetcher on-off settings. Options include: Enabled Disabled This function can judge whether there is data to prefetch, to shorten the data reading time.	Enabled
LLC Prefetcher	All threads LLC prefetcher on-off settings. Options include: Enabled Disabled	Disabled
DCU Mode	DCU mode settings. Options include: 32KB 8Way Without ECC 16KB 4Way With ECC	32KB 8Way Without ECC
Extended APIC	Extended APIC on-off settings. Options include: Enabled Disabled	Enabled
AES-NI	AES instruction on-off settings. Options include: Enabled Disabled This menu mainly controls whether the CPU supports AES instruction. These instructions are mainly used for system virtualization. Enable this instruction, system performance will be improved.	Enabled

8.2.4.2 Common Configuration

Common Configuration interface is used to set the common options.

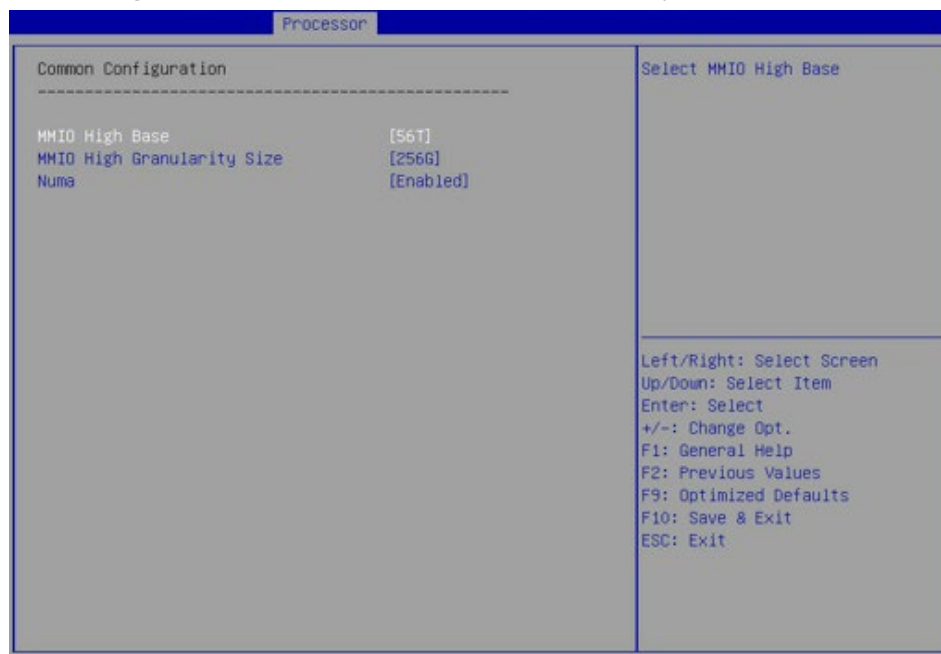

Figure 8-49

Table 8-25 Common Configuration Interface Instruction Table

Interface Parameters	Function Description	Default Value
MMIO High Base	MMIO high base settings. Options include: 56T 40T 24T 16T 4T 1T	56T
MMIO High Granularity Size	MMIO high granularity size settings. Options include: 1G 4G 16G 64G 256G 1024G	256G
Numa	Numa on-off settings. Options include: Enabled Disabled	Enabled

8.2.4.3 UPI Configuration

UPI Configuration interface is used to set the options related with UPI.

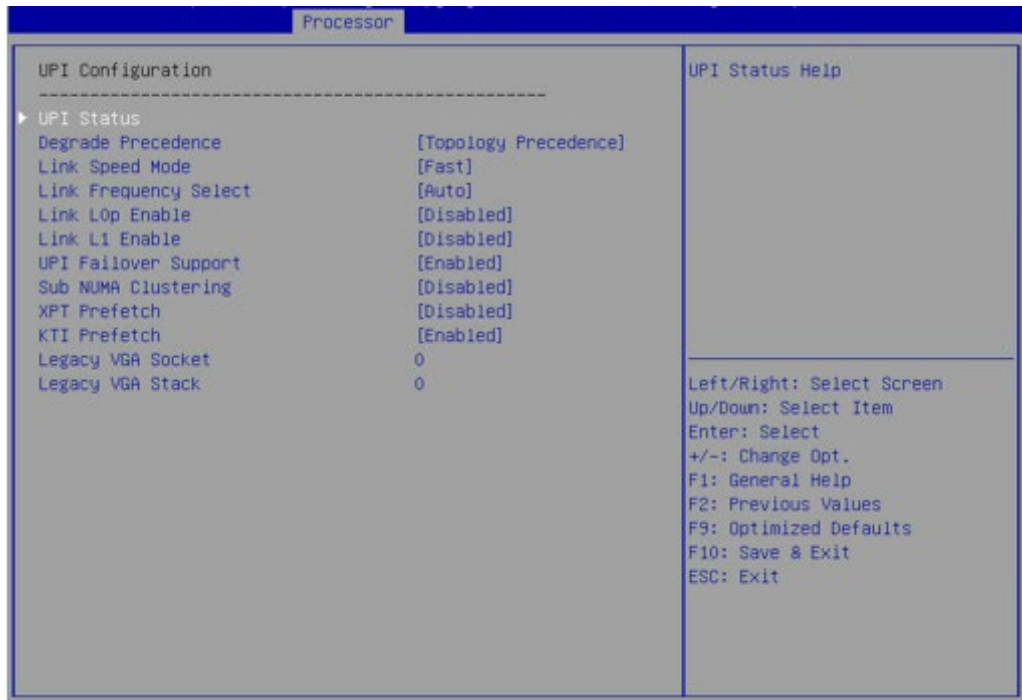

Figure 8-50

Table 8-26 UPI Configuration Interface Instruction Table

Interface Parameters	Function Description	Default Value
UPI Status	UPI status submenu, displaying the current UPI link status	----
Degradate Precedence	Degradate precedence settings. Options include: Topology Precedence Feature Precedence When the system settings conflict, set it to Topology Precedence to reduce Feature; or set it to Feature Precedence to reduce Topology.	Topology Precedence
Link Speed Mode	Link speed mode settings. Options include: Fast Slow	Fast
Link Frequency Select	Link frequency select settings. Options include: Auto 9.6 GT/s 10.4GT/s Use Per Link Setting	Auto
Link L0p Enable	Link L0p on-off settings. Options include: Enabled Disabled Link power-saving mode setting, which is set when the bandwidth is half of the peak bandwidth	Disabled
Link L1 Enable	Link L1 on-off settings. Options include: Enabled Disabled In the case that system is extremely idle, turn off QPI Link.	Disabled

UPI Failover Support	UPI failover support on-off settings. Options include: Enabled Disabled	Enabled
Sub NUMA Clustering	Sub NUMA cluster settings. Options include: Auto: Support 1-cluster or 2-clusters according to IMC interleave. Enabled: Support all SNC clusters (2-clusters) and 1-way IMC interleave. Disabled: SNC function not supported.	Disabled
Legacy VGA Socket	Legacy VGA number settings, the range of effective values is 0~1.	0
Legacy VGA Stack	Legacy VGA stack number settings, the range of effective values is 0~6.	0

8.2.4.4 Memory Configuration

Memory Configuration interface is used to set the options related with the memory.

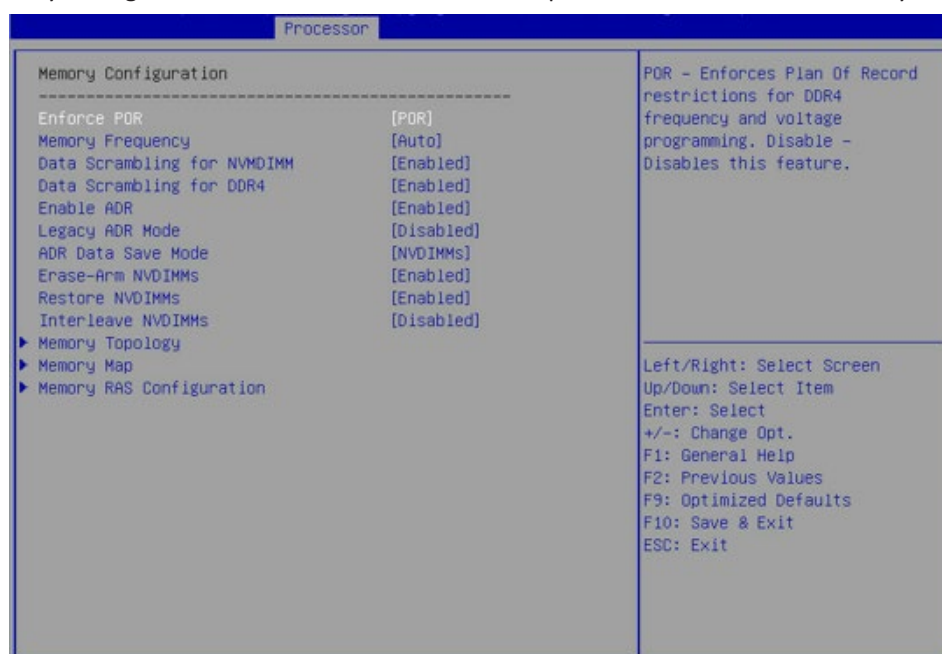

Figure 8-51

Table 8-27 Memory Configuration Interface Instruction Table

Interface Parameters	Function Description	Default Value
Enforce POR	Enforce POR settings. Options include: POR Disabled	POR
Memory Frequency	Memory frequency settings. Options include: Auto 1600 1866 2133 2400 2666	Auto

Data Scrambling for NVMDIMM	NVMDIMM data scrambling on-off settings. Options include: Enabled Disabled	Enabled
Data Scrambling for DDR4	DDR4 data scrambling on-off settings. Options include: Auto Enabled Disabled	Enabled
Enable ADR	ADR on-off settings. Options include: Enabled Disabled	Enabled
Legacy ADR Mode	Legacy ADR mode on-off settings. Options include: Enabled Disabled	Enabled
ADR Data Save Mode	ADR data save mode settings. Options include: Disabled Batterybacked DIMMs NVDIMMs	NVDIMMS
Erase-Arm NVDIMMs	Erase-Arm NVDIMMs on-off settings. Options include: Enabled Disabled	Enabled
Restore NVDIMMs	Restore NVDIMMs on-off settings. Options include: Enabled Disabled	Enabled
Interleave NVDIMMs	Interleave NVDIMMs on-off settings. Options include: Enabled Disabled	Disabled
Memory Topology	Memory topology submenu, displaying the detailed information of the current installed memories.	----
Memory Map	Memory Map submenu	----
Memory RAS Configuration	Memory RAS configuration submenu	----

8.2.4.4.1 Memory Map

Memory Map interface is used to set some modes of the memory.

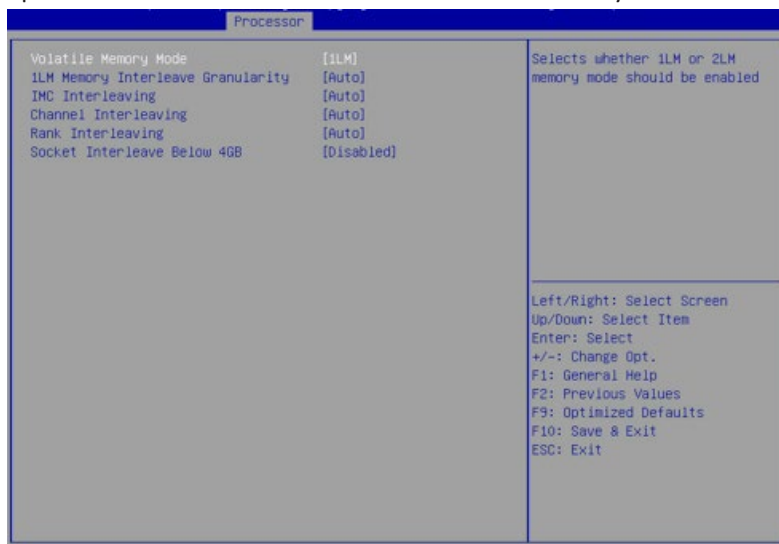

Figure 8-52

Table 8-28 Memory Map Interface Instruction Table

Interface Parameters	Function Description	Default Value
Volatile Memory Mode	Volatile memory mode settings. Options include: 1LM 2LM Auto	1LM
1LM Memory Interleave Granularity	1LM memory interleave granularity settings. Options include: Auto 256B Target, 256B Channel 64B Target, 64B Channel	Auto
IMC Interleaving	IMC interleaving settings. Options include: Auto 1-way Interleave 2-way Interleave	Auto
Channel Interleaving	Channel interleaving settings. Options include: Auto 1-way Interleave 2-way Interleave 3-way Interleave	Auto
Rank Interleaving	Rank interleaving settings. Options include: Auto 1-way Interleave 2-way Interleave 4-way Interleave 8-way Interleave	Auto
Socket Interleave Below 4GB	On-off settings of 4GB or less address space processor interleave. Options include: Enabled Disabled	Disabled

8.2.4.4.2 Memory RAS Configuration

Memory RAS Configuration interface is used to set the options related with the memory RAS feature.

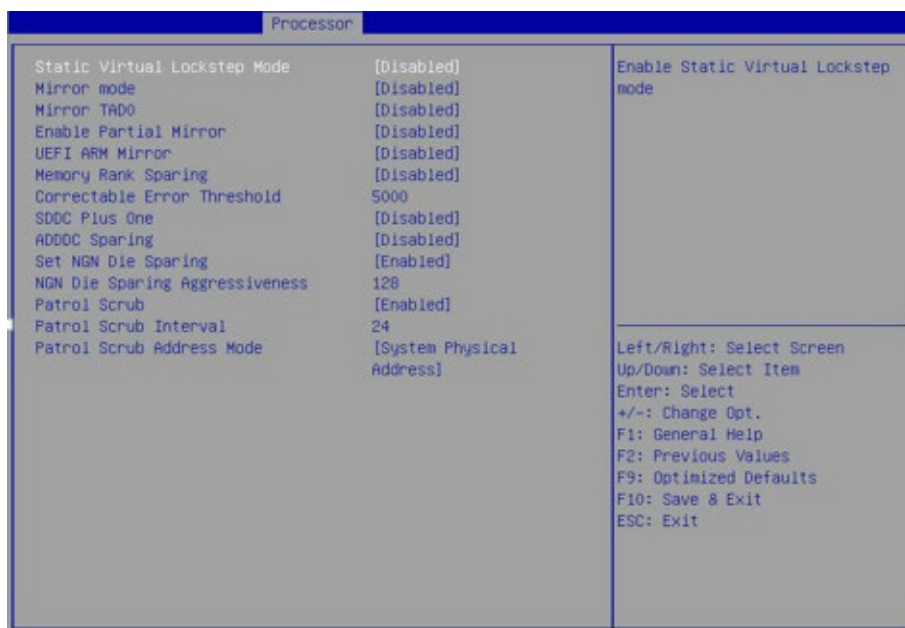

Figure 8-53

Table 8-29 Memory RAS Configuration Interface Instruction Table

Interface Parameters	Function Description	Default Value
Static Virtual Lockstep Mode	Static virtual lockstep mode on-off settings. Options include: Enabled Disabled	Disabled
Mirror Mode	Mirror mode settings. Options include: Disabled Mirror Mode 1LM Mirror Mode 2LM	Disabled
Mirror TAD0	Mirror TAD0 mode on-off settings. Options include: Enabled Disabled	Disabled
Enable Partial Mirror	Enable partial mirror mode. Options include: Disabled Partial Mirror mode 1LM Partial Mirror mode 2LM	Disabled
UEFI ARM Mirror	UEFI ARM mirror mode on-off settings. Options include: Enabled Disabled	Disabled
Memory Rank Sparing	Memory Rank sparing on-off settings. Options include: Enabled Disabled When it is set to Enabled, users can select the memory sparing mode. It is a kind of memory channel sparing in Rank, the total memory capacity varies with sparing modes, and it supports at most half of the memory capacity to be used for sparing.	Disabled
Correctable Error Threshold	Correctable error threshold settings	2
SDDC Plus One	SDDC+1 on-off settings. Options include: Enabled Disabled	Disabled
ADDDC Sparing	ADDDC sparing on-off settings. Options include: Enabled Disabled	Disabled
Set NGN Die Sparing	NGN Die sparing on-off settings. Options include: Enabled Disabled	Enabled
NGN Die Sparing Aggressiveness	NGN Die sparing aggressiveness settings, the value range is 0~255, and 0 means no sparing Die.	128
Patrol Scrub	Patrol Scrub on-off settings. Options include: Enabled Disabled	Enabled
Patrol Scrub Interval	Patrol Scrub interval settings, the unit is hour and the range is 0~24.	24
Patrol Scrub Address Mode	Patrol Scrub address mode settings. Options include: System Physical Address Reverse Address	System Physical Address

8.2.4.5 IIO Configuration

IIO Configuration interface is used to set the options related with the PCIe sockets.

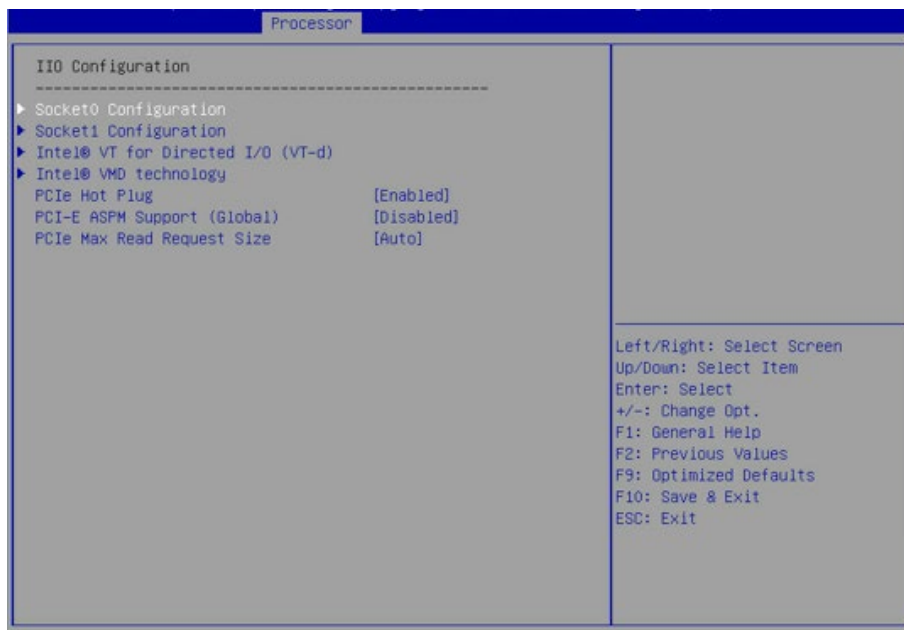

Figure 8-54

Table 8-30 IIO Configuration Interface Instruction Table

Interface Parameters	Function Description	Default Value
SocketN Configuration	Socket N configuration submenu, used to set the Link speed, Max Payload Size and ASPM of the CPU's PCIE device, and to display the link status, maximum link and current link speed of the PCIE port.	----
Intel VT for Directed I/O (VT-d)	Intel VT-d settings submenu, Intel VT-d on-off settings	----
Intel VMD Technology	Intel VMD settings submenu, VMD on-off settings of each PStack of each CPU.	----
Intel AIC Retimer/AIC SSD Technology (Non-VMD)	Intel AIC Retimer/AIC SSD settings submenu, AIC Retimer/AIC SSD on-off settings of each PStack of each CPU.	----
PCIe Hot Plug	PCIe hot plug on-off settings. Options include: Enabled Disabled	Enabled
PCI-E ASPM Support (Global)	PCI-E ASPM support on-off settings. Options include: Disabled Per-Port L1 Only	Disabled
PCIe Max Read Request Size	PCIe max read request size settings. Options include: Auto 128B 256B 512B 1024B 2048B 4096B	Auto

8.2.4.6 Advanced Power Management Configuration

Advanced Power Management Configuration interface is used to set the options related with the CPU power management.

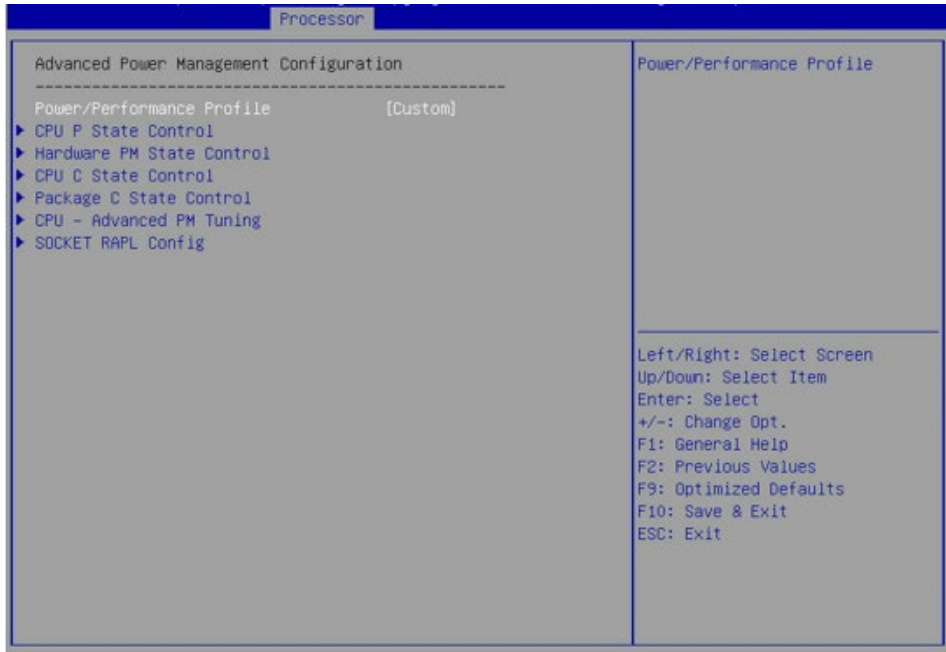

Figure 8-55

Table 8-31 Advanced Power Management Configuration Interface Instruction Table

Interface Parameters	Function Description
CPU P State Control	CPU P state control submenu
Hardware PM State Control	Hardware PM state control submenu
CPU C State Control	CPU C state control submenu
Package C State Control	Package C state control submenu
CPU-Advanced PM Tuning	CPU power-saving performance tuning submenu
Socket RAPL Configuration	Socket RAPL configuration submenu

8.2.4.6.1 CPU P State Control

CPU P State Control interface is used to set the options related with the CPU P state.

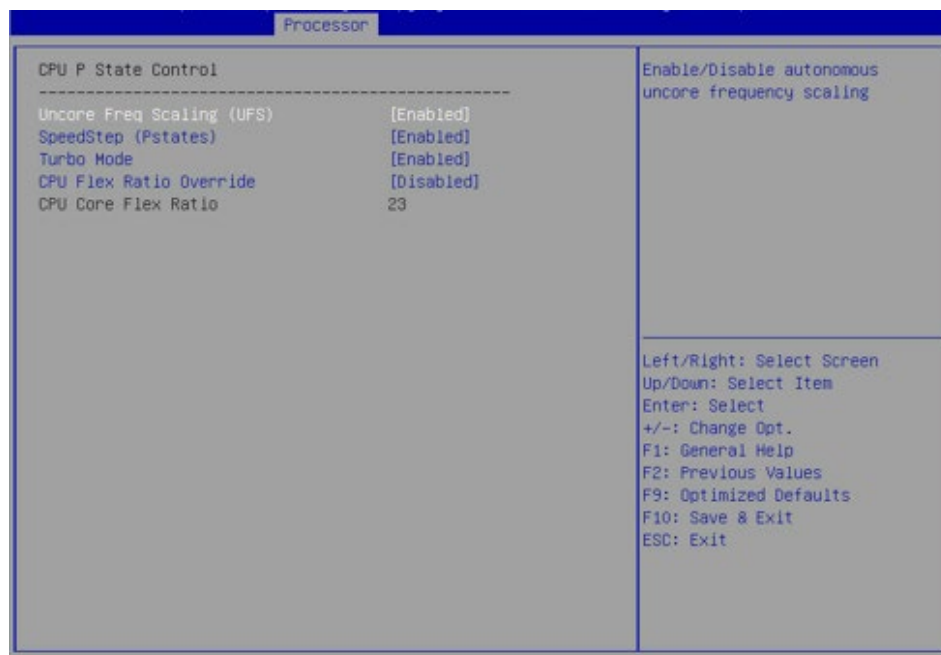

Figure 8-56 Table

8-32 CPU P State Control Interface Instruction Table

Interface Parameters	Function Description	Default Value
UncoreFreq Scaling (UFS)	Uncore frequency scaling settings. Options include: Enabled Disabled (Min Frequency) Disabled (MAX Frequency) Custom	Enabled
Uncore Frequency	Uncore frequency settings. The range is 1300-2300, displayed whenUncoreFreq Scaling (UFS) is set to Custom.	1300
SpeedStep (Pstates)	SpeedStep on-off settings. Options include: Enabled Disabled	Enabled
Turbo Mode	Turbo mode on-off settings. Options include: Enabled Disabled	Enabled

8.2.4.6.2 Hardware PM State Control

Hardware PM State Control interface is used to set the options related with the hardware PM state.

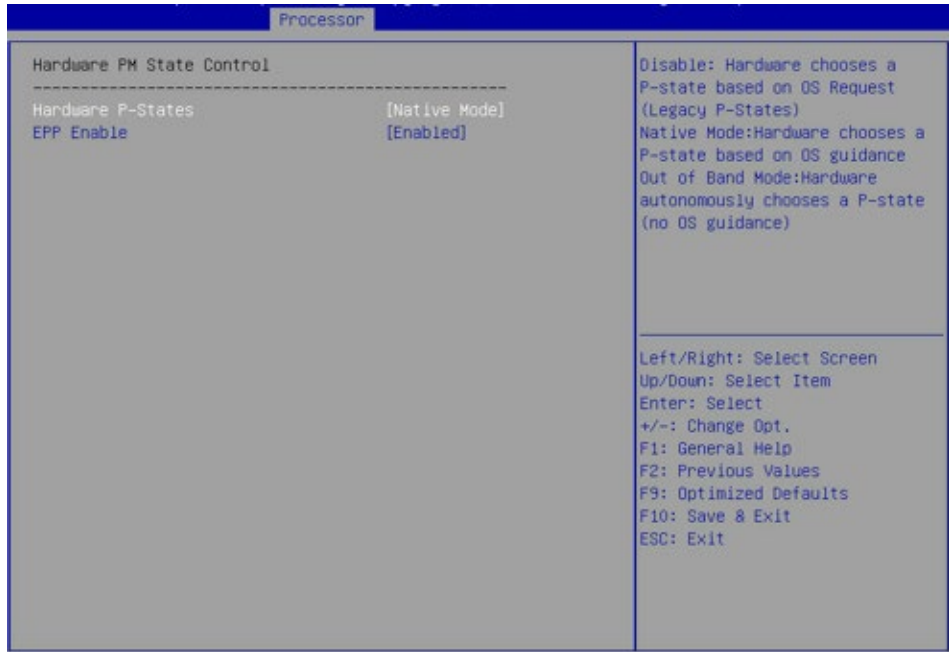

Figure 8-57

Table 8-33 Hardware PM State Control Interface Instruction Table

Interface Parameters	Function Description	Default Value
Hardware P-States	Hardware P-States is set by OS automatically or not, the default value is decided based on the actual test. Options include: Disabled: based on legacy OS request Native Mode: based on legacy OS boot Out of Band Mode: hardware auto select, no OS boot Native Mode with No Legacy Support	Native Mode
EPP Enable	EPP on-off settings. Options include: Enabled Disabled	Enabled

8.2.4.6.3 CPU C State Control

CPU C State Control interface is used to set the options related with the CPU C state, for controlling the power consumption of CPU in idle state.

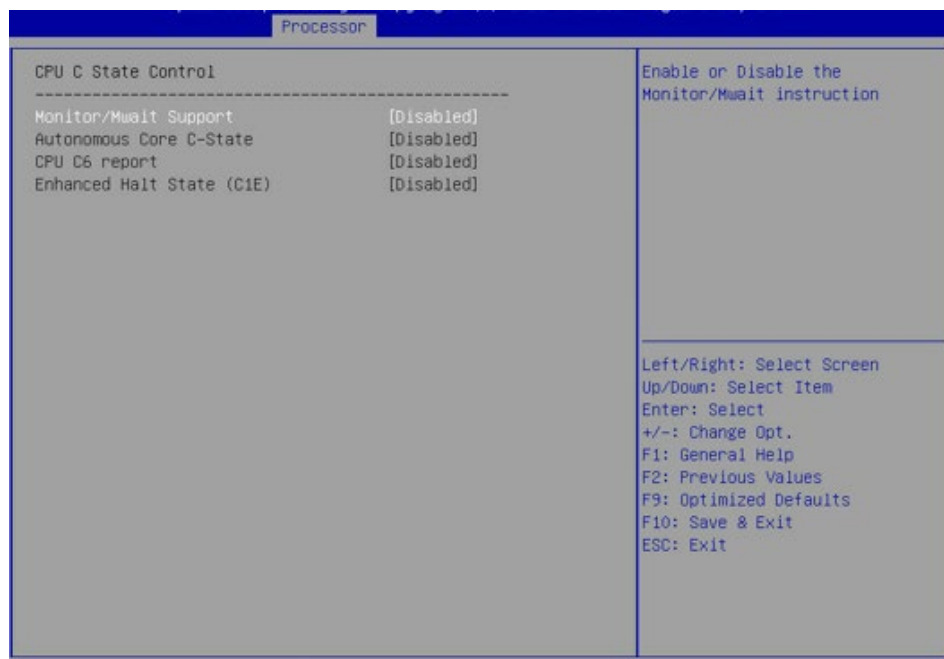

Figure 8-58

Table 8-34 CPU C State Control Interface Instruction Table

Interface Parameters	Function Description	Default Value
Monitor/Mwait Support	Monitor/Mwait support on-off settings. Options include: Enabled Disabled	Disabled
Autonomous Core C-State	Autonomous core C-state on-off settings. Options include: Enabled Disabled	Disabled
CPU C6 report	On-off settings of reporting C6 state to OS. Options include: Enabled Disabled	Disabled
Enhanced Halt State (C1E)	C1E on-off settings. Options include: Enabled Disabled	Disabled

8.2.4.6.4 Package C State Control

Package C State Control interface is used to set the options related to the Package C state.

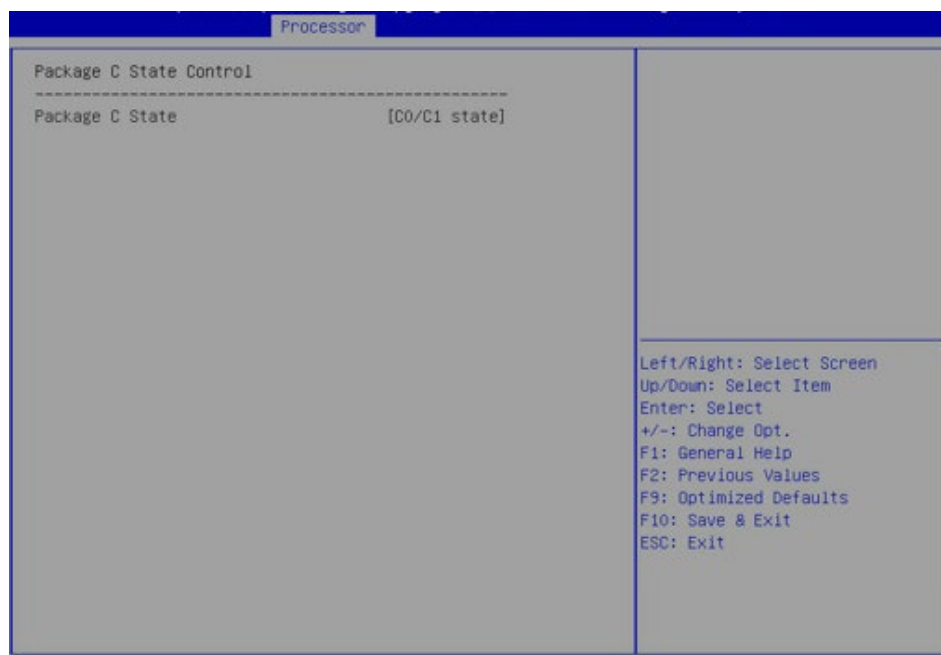

Figure 8-59

Table 8-35 Package C State Control Interface Instruction Table

Interface Parameters	Function Description	Default Value
Package C State	Package C state settings. Options include: C0/C1 state C2 state C6 (Non Retention) state C6 (Retention) state No Limit	C0/C1 state

8.2.4.6.5 CPU-Advanced PM Tuning

CPU-Advanced PM Tuning interface is used to set the options related with the CPU power-saving performance, with an Energy Perf BIAS submenu.

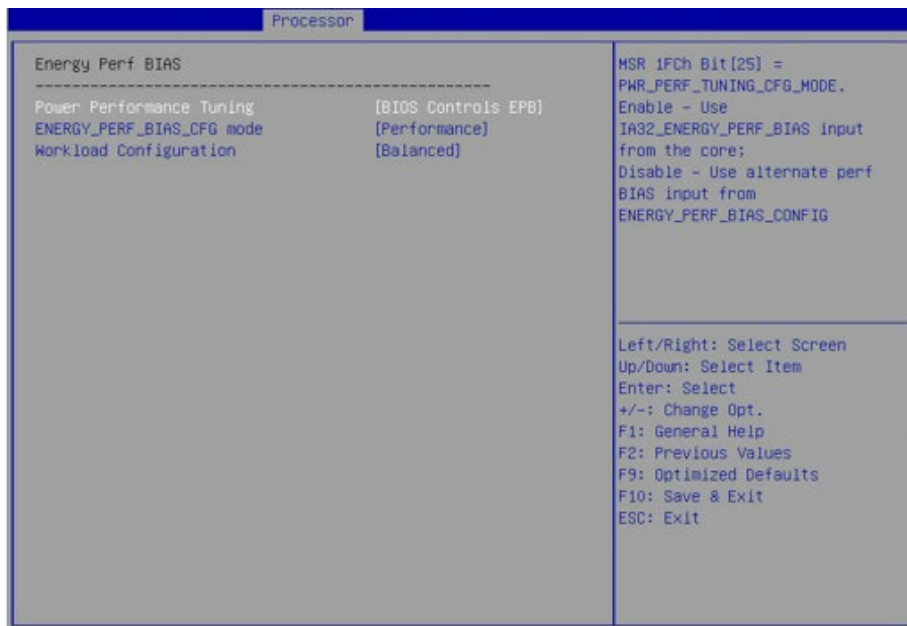

Figure 8-60

Table 8-36 Energy Perf BIAS Interface Instruction Table

Interface Parameters	Function Description	Default Value
Power Performance Tuning	Power performance tuning settings. Options include: OS Controls EPB BIOS Controls EPB	OS Controls EPB
ENERGY_PERF_BIAS_CFG Mode	Power performance management settings. Options include: Performance Balanced Performance Balanced Power Power When the Power Performance Tuning is set to BIOS Controls EPB, this option can be set.	Performance
Workload Configuration	Workload optimization settings. Options include: UMA NUMA	

8.2.5 Sever Mgmt

Server Mgmt interface is used to set the options related with server management, including watchdog, BMC network configuration, BMC user settings, system health information, etc.

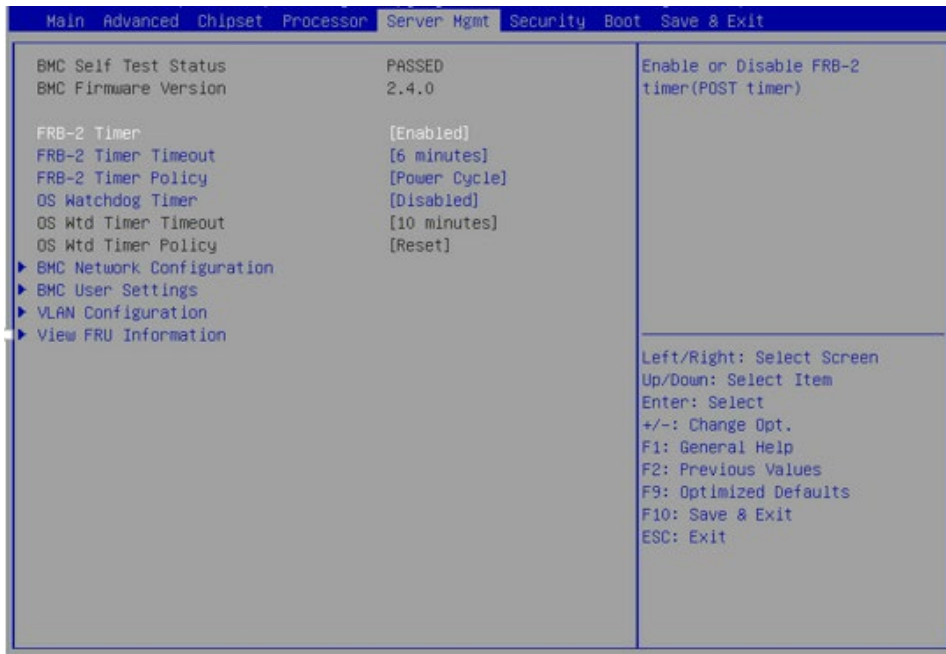

Figure 8-61

Table 8-37 Server Mgmt Interface Instruction Table

Interface Parameters	Function Description	Default Value
BMC Self Test Status	BMC self-test status	----
BMC Firmware Version	Current motherboard's BMC firmware version	----
FRB-2 Timer	FRB-2 timer on-off settings. Options include: Enabled Disabled	Enabled
FRB-2 Timer Timeout	FRB-2 timer timeout settings. Options include: 3 minutes 4 minutes 5 minutes 6 minutes	6 minutes
FRB-2 Timer Policy	FRB-2 timer policy settings. Options include: Do Nothing Reset Power Down Power Cycle	Power Cycle
OS Watchdog Timer	OS watchdog timer settings. Options include: Enabled Disabled	Disabled
OS Wtd Timer Timeout	OS watchdog timer timeout settings. Options include: 5 minutes 10 minutes 15 minutes 20 minutes	10 minutes

OS Wtd Timer Policy	OS watchdog timer policy settings. Options include: Do Nothing Reset Power Down Power Cycle	Reset
BMC Network Configuration	BMC network configuration submenu	----
BMC User Settings	BMC user settings submenu	----
VLAN Configuration	VLAN configuration submenu	----
View FRU Information	View FRU information submenu	----

8.2.5.1 BMC Network Configuration

BMC Network Configuration interface is used to configure the BMC network through BIOS.

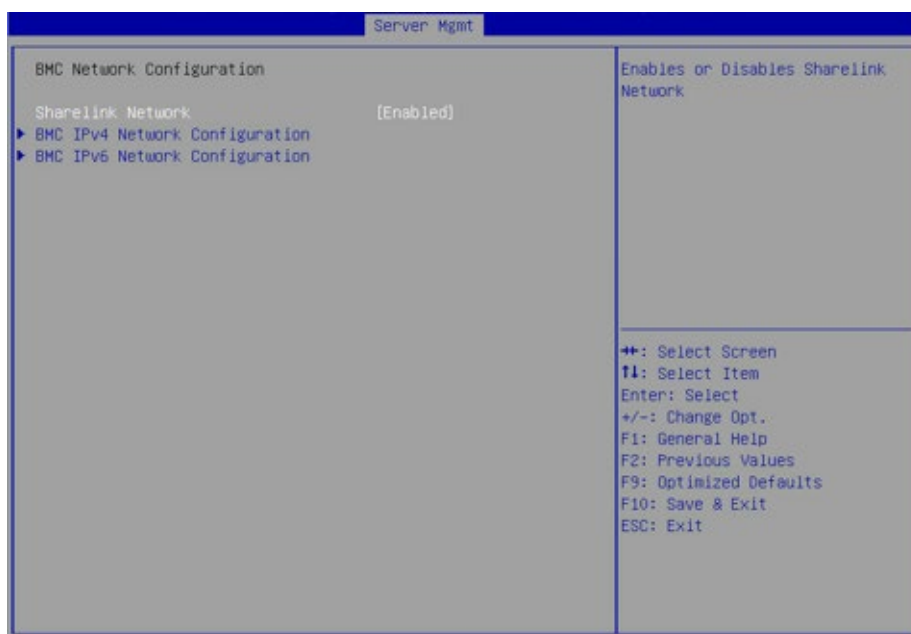

Figure 8-62

Table 8-38 BMC Network Configuration Interface Instruction Table

Interface Parameters	Function Description	Default Value
Sharelink Network	BMC Sharelink network on-off settings, take effect immediately.	Enabled
BMC IPv4 Network Configuration	BMC IPv4 network configuration	----
BMC IPv6 Network Configuration	BMC IPv6 network configuration	----

8.2.5.1.1 BMC IPv4 Network Configuration

BMC IPv4 Network Configuration interface is used to configure the BMC IPv4 management network through BIOS.

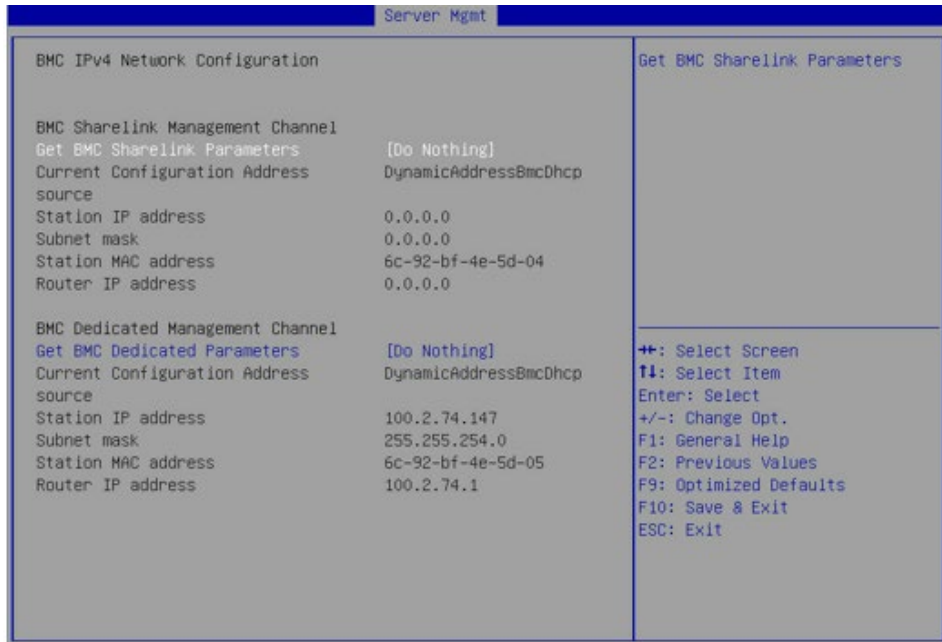

Figure 8-63

Table 8-39 BMC IPv4 Network Configuration Interface Instruction Table

Interface Parameters	Function Description	Default Value
Get BMC Sharelink/Dedicated Parameters	Set the method to get the BMC sharelink/dedicated parameters. Options include: Do Nothing Auto Manual	Do Nothing
Configuration Address Source	Set BMC network status. Options include: Unspecified Static DynamicBmcDhcp The setting takes effect immediately.	Unspecified
Current Configuration Address	Current BMC configuration address status	----
Station IP address	Station IP address	----
Subnet mask	Subnet mask	----
Station MAC address	Station MAC address	----
Router IP address	Router IP address	----

8.2.5.1.2 BMC IPv6 Network Configuration

BMC IPv6 Network Configuration interface is used to configure the BMC IPv6 management network through BIOS.

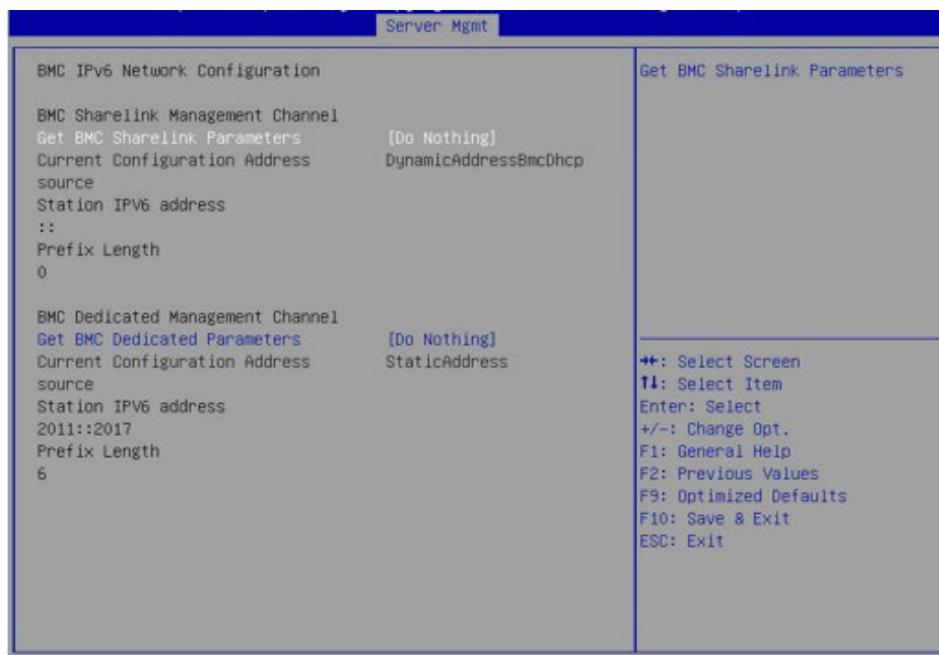

Figure 8-64

Table 8-40 BMC IPv6 Network Configuration Interface Instruction Table

Interface Parameters	Function Description	Default Value
Get BMC Sharelink/Dedicated Parameters	Set the method to get the BMC sharelink/dedicated parameters. Options include: Do Nothing Auto Manual	Do Nothing
Configuration Address Source	Set BMC network status. Options include: Unspecified Static DynamicBmcDhcp The setting takes effect immediately.	Unspecified
Current Configuration Address	Current BMC configuration address status	----
Station IPv6 address	Station IPv6 address	----
Prefix Length	IPv6 prefix length	----

8.2.5.2 BMC User Settings

BMC User Settings interface is used to configure BMC users through BIOS.

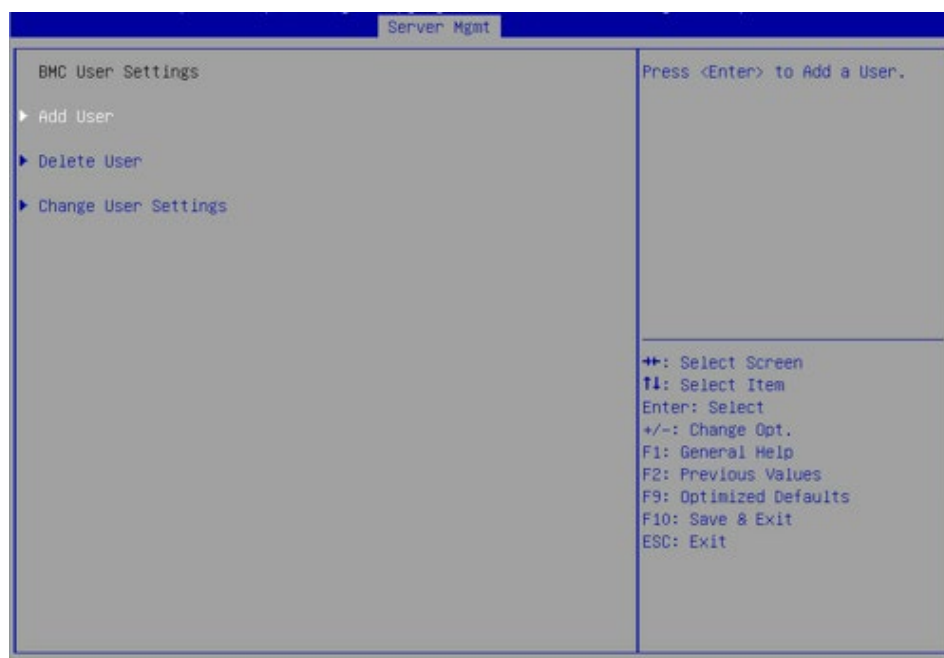

Figure 8-65

Table 8-41 BMC User Settings Interface Instruction Table

Interface Parameters	Function Description
Add User	Add user submenu
Delete User	Delete user submenu
Change User Settings	Change user settings submenu

8.2.5.2.1 Add User

Add User interface is used to add a BMC user through BIOS. The addition takes effect immediately, and the user will be added to the BMC user list.

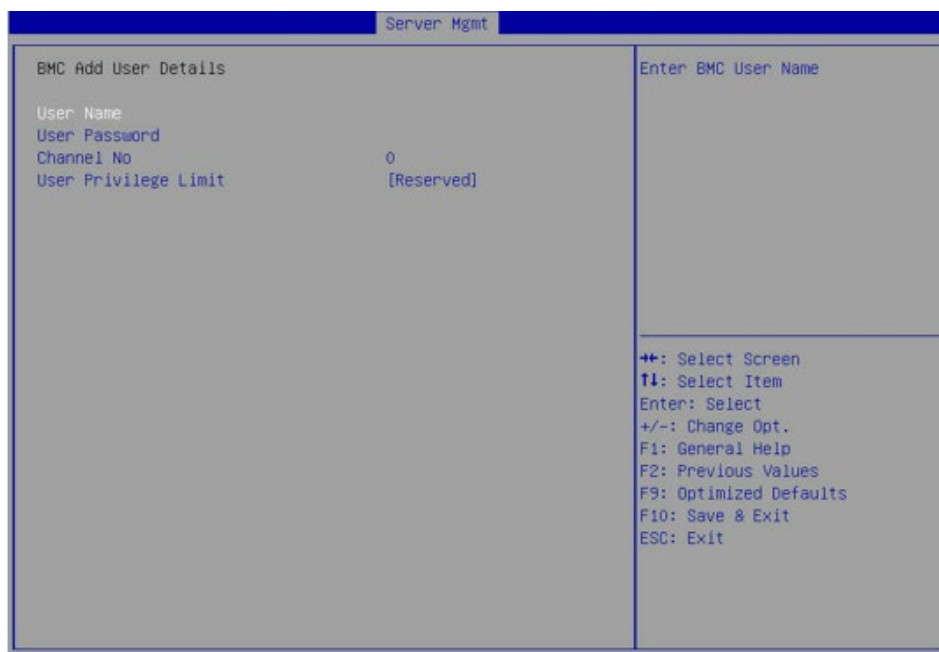



Figure 8-66

Table 8-42 Add User Interface Instruction Table

Interface Parameters	Function Description	Default Value
User Name	Set user name, supporting up to 16 characters.	----
User Password	Set user password. It must contain uppercase and lowercase letters, special characters and numbers, within 8-20 characters.	----
Channel NO	Set BMC channel, input 1 or 8.	----
User Privilege Limit	User privilege settings. Options include: Reserved Callback User Operator Administrator If the setting succeeds, it will prompt "Set User Access Command Passed", and the BMC User takes effect immediately.	Reserved

 **Note:** To enable the new user, it needs to set the User option in the Change User Settings interface to [Enabled], and then this user can login to the BMC Web interface.

8.2.5.2.2 Delete User

Delete User interface is used to delete a BMC user through BIOS. The deletion takes effect immediately, and this user can not login to the BMC Web interface any more.

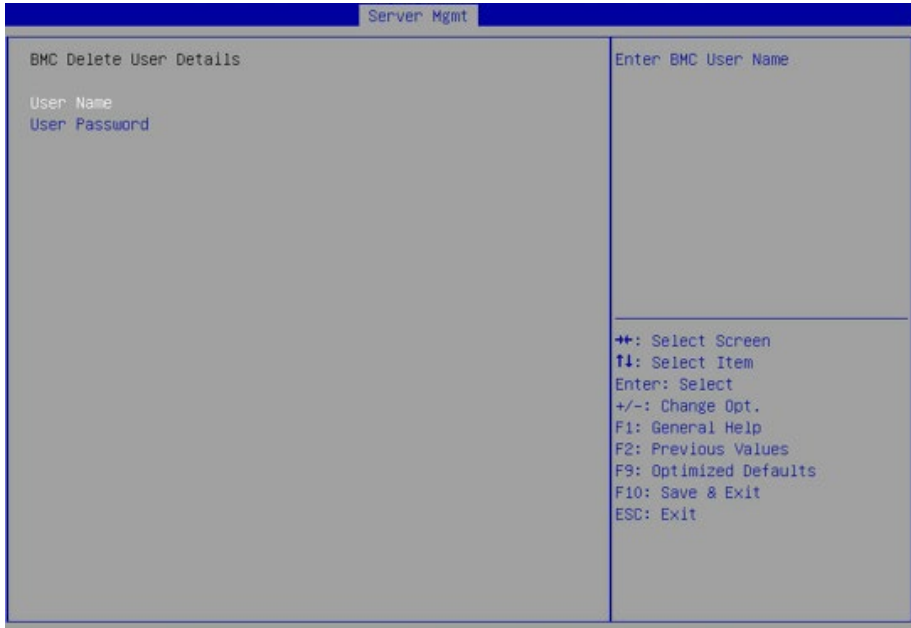

Figure 8-67

Table 8-43 Delete User Interface Instruction Table

Interface Parameters	Function Description
User Name	Input the name of user to delete
User Password	Input the password of user to delete. If the password is correct, it pops up “User Deleted!!!” The deletion takes effect immediately in BMC, and this user can not login to the BMC Web interface any more.

8.2.5.2.3 Change User Settings

Change User Settings interface is used to modify the BMC user settings through BIOS.

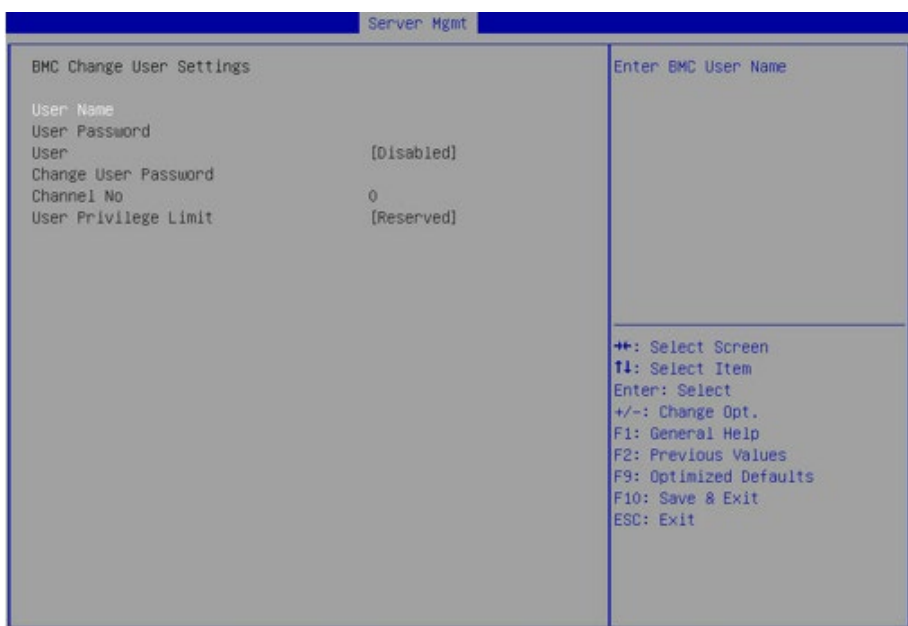

Figure 8-68

Table 8-44 Change User Settings Interface Instruction Table

Interface Parameters	Function Description	Default Value
User Name	Input the name of user to modify	----
User Password	Input the password of user to modify. Only both the name and password are correct, the following options can be modified.	----
User	User privilege on-off settings. Options include: Enabled Disabled	Disabled
Change User Password	Change the user password. It must contain uppercase and lowercase letters, special characters and numbers, within 8-20 characters.	----
Channel NO	Set BMC channel, input 1 or 8.	0
User Privilege Limit	Modify the user privilege. Options include: Reserved Callback User Operator Administrator	Reserved

8.2.5.3 VLAN Configuration

VLAN Configuration interface is used to set the BMC VLAN parameters through BIOS.

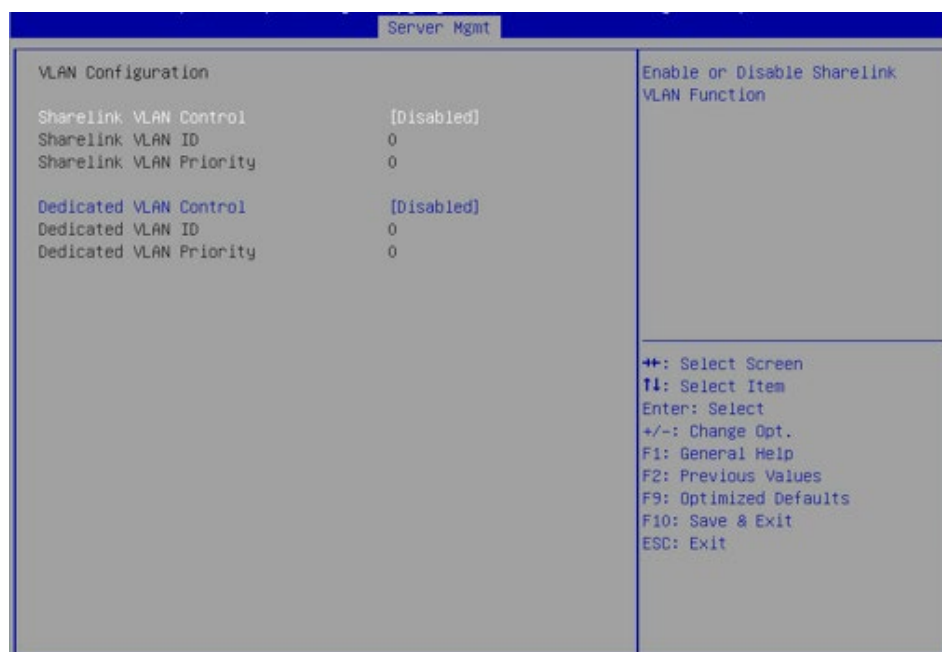

Figure 8-69

Table 8-45 VLAN Configuration Interface Instruction Table

Interface Parameters	Function Description	Default Value
Sharelink/Dedicated VLAN Control	BMC sharelink/dedicated VLAN control on-off settings. Options include: Enabled Disabled To enable VLAN, it needs to set the VLAN ID first.	Disabled
Sharelink/Dedicated VLAN ID	BMC sharelink/dedicated VLAN ID settings, the range is 2~4094. The setting takes effect immediately.	0
Sharelink/Dedicated VLAN Priority	BMC sharelink/dedicated VLAN priority settings, the range is 1~7. The setting takes effect immediately.	0

8.2.5.4 View FRU Information

View FRU Information interface displays the BMC FRU information read by BIOS. On each system reboot, BIOS interacts with BMC to keep the FRU information synchronized.

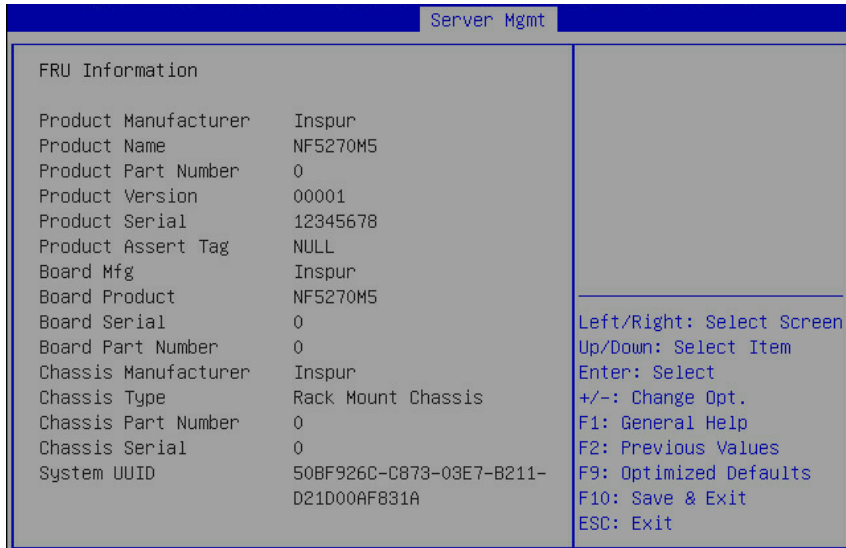

Figure 8-70

Table 8-46 View FRU Information Interface Instruction Table

Interface Parameters	Function Description
System Manufacturer	System manufacturer
System Product Name	System product name
System Product Part Number	System product part number
System Version	System version
System Serial Number	System serial number
Board Manufacturer	Board manufacturer
Board Product Name	Board product name
Board Serial Number	Board serial number
Board Part Number	Board part number
Chassis Manufacturer	Chassis manufacturer
Chassis Product Name	Chassis product name
Chassis Serial Number	Chassis serial number

8.2.6 Security

Security interface is used to set the password of the administrator and user.

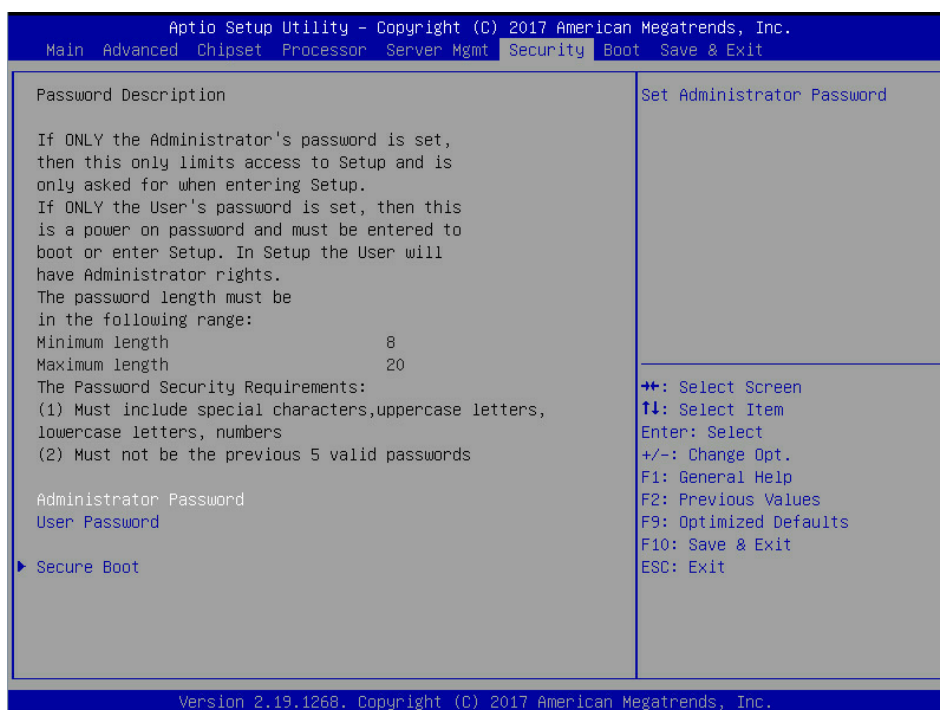

Figure 8-71

Table 8-47 Security Interface Instruction Table

Interface Parameters	Function Description
Administrator Password	Create an administrator password. It must contain uppercase and lowercase letters, special characters and numbers, within 8-20 characters.
User Password	Create a user password. It must contain uppercase and lowercase letters, special characters and numbers, within 8-20 characters.
Secure Boot	Secure boot menu

8.2.7 Boot

Boot interface is used to set the options related with system boot, including boot mode, boot priority, boot procedure, etc.

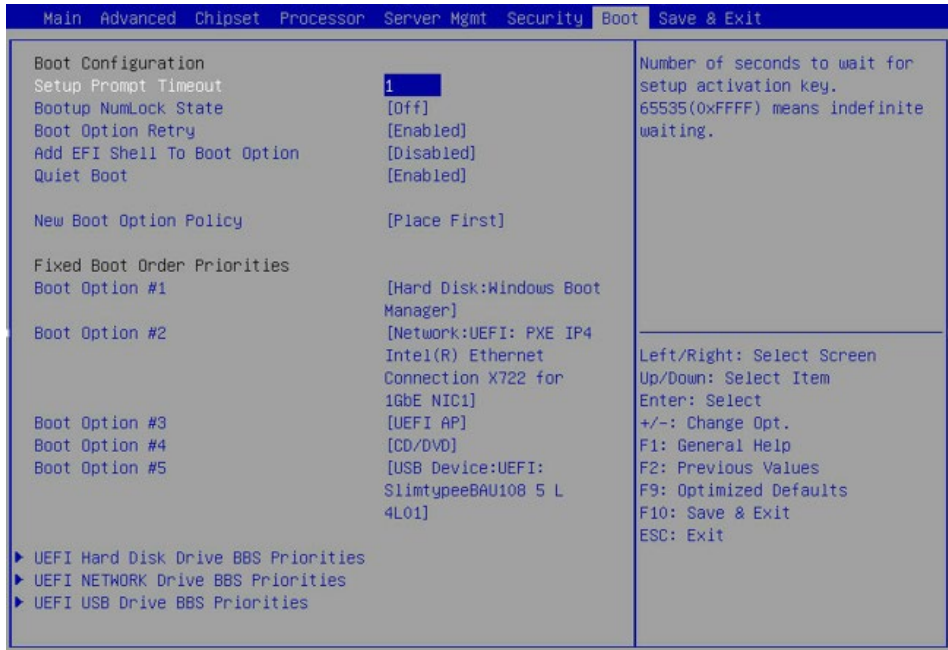

Figure 8-72

Table 8-48 Boot Configuration Interface Instruction Table

Interface Parameters	Function Description	Default Value
Setup Prompt Timeout	Setup prompt timeout settings. Set the time to wait for the Setup activate key, and the maximum value is 65535 seconds.	1
Bootup NumLock State	BootupNumlock state on-off settings. Options include: On Off	Off
Boot Options Retry	Boot options retry on-off settings. Options include: Enabled Disabled	Enabled
Quiet Boot	Quiet boot on-off settings. Options include: Enabled Disabled If it is set to Enabled, the boot logo displays as that set by manufacturer, if set to Disabled, the boot screen displays as the text-mode POST interface.	Enabled
New Boot Option Policy	New UEFI boot option policy settings. Options include: Default Place First Place Last	Place First
Fixed Boot Order Priorities Boot Option #X	Boot options priority settings	----
XXXX Driver BBS Priorities	XXXX driver BBS priority settings	---

8.2.8 Save & Exit

Save & Exit interface is used to set the options related with BIOS parameters saving and exit.

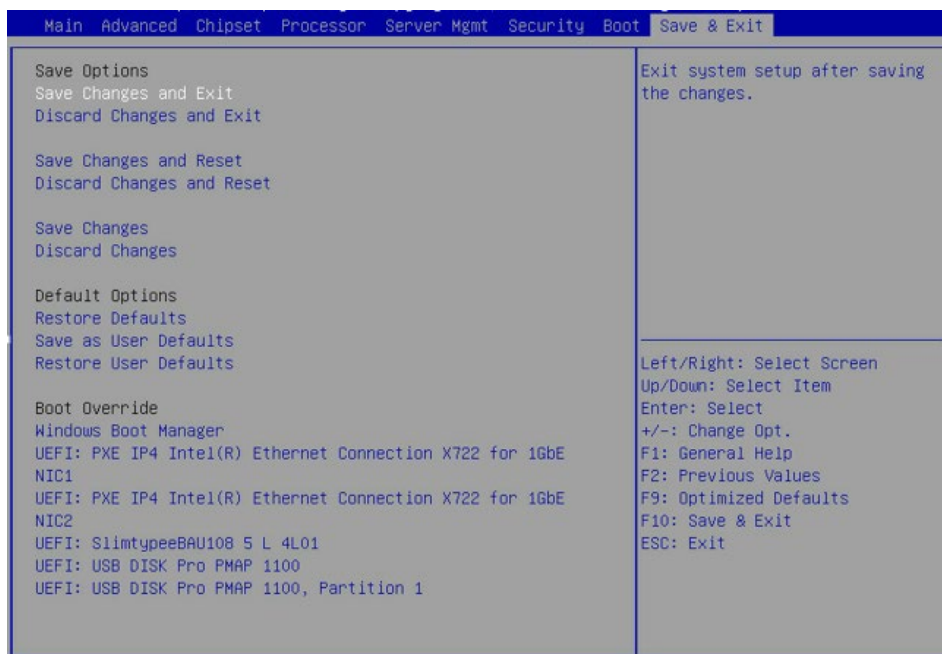

Figure 8-73

Table 8-49 Save & Exit Interface Instruction Table

Interface Parameters	Function Description
Save Changes and Exit	To save changes and exit
Discard Changes and Exit	To discard changes and exit
Save Changes and Reset	To save changes and reset
Discard Changes and Reset	To discard changes and reset
Save Changes	To save changes
Discard Changes	To discard changes
Restore Defaults	To restore defaults
Save as User Defaults	To save as user defaults
Restore User Defaults	To restore user defaults
Boot Override	To override the boot option, you could select the boot device from the following options

8.3 Firmware Update

For BIOS update, you could select to update in UEFI Shell or OS.

8.3.1 Update BIOS in UEFI Shell

- 1) When Inspur Logo appears on the screen during system booting, there is a prompt “Press to SETUP or <TAB> to POST or <F11> to Boot Menu or <F12> to PXE Boot” below. Press F11 key to open the Boot Menu, as shown in the following figure. Enter the item: UEFI: Built-in EFI Shell.

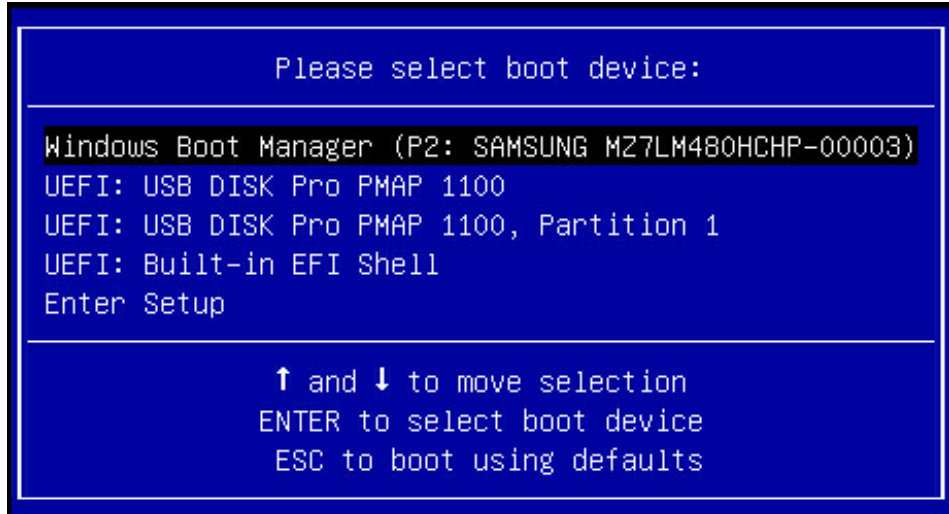

Figure 8-74

2) Enter the disk where the AfuEfi64 package resides, and enter the AfuEfi64 folder. The BIOS.bin file is the 32M BIOS+ME file to update, as shown in the following figure.

```
fs0:\> cd afuefi64

fs0:\afuefi64> dir
Directory of: fs0:\afuefi64

10/24/14  09:34a <DIR>          4,096  .
10/24/14  09:34a <DIR>           0     ..
04/14/15  09:56a             16,777,216  BIOS.bin
02/02/15  02:58p             405,104    AfuEfix64.efi
          2 File(s)  17,182,320 bytes
          2 Dir(s)
```

Figure 8-75

3) When there is no change in ME part, execute the command to update 16M BIOS: AfuEfix64.efi BIOS.bin /b /p /n /x /k /l, and the process is as shown in the following figure. After the update is completed, it is recommended to power cycle the system.

```

FS1:\AfuEfi64\> AfuEfix64.efi BIOS.bin /B /P /N /X /K /L
-----
|               AMI Firmware Update Utility v5.09.01.1317               |
|       Copyright (C)2017 American Megatrends Inc. All Rights Reserved.   |
|-----|
Reading flash ..... done
- ME Data Size checking . ok
Secure Flash enabled, recalculate ROM size with signature... Enable.
- FFS checksums ..... ok
- Check RomLayout ..... OK.
Loading capsule to secure memory buffer ... done
Erasing Boot Block ..... done
Updating Boot Block ..... done
Verifying Boot Block ..... done
Erasing Main Block ..... done
Updating Main Block ..... done
Verifying Main Block ..... done
Erasing NVRAM Block ..... done
Updating NVRAM Block ..... done
Verifying NVRAM Block ..... done
Erasing NCB Block ..... done
Updating NCB Block ..... done
Verifying NCB Block ..... done
Erasing RomHole Block ..... done
Updating RomHole Block ..... done
Verifying RomHole Block ..... done

```

Figure 8-76

4) If there are any changes in ME part, execute the command to update 32M ME+BIOS: AfuEfix64.efi BIOS.bin /b /p /n /x /k /l /me, and the process is as shown in the following figure.

Parameter instructions:

- /B Program Boot Block
- /P Program main bios image
- /N Program NVRAM
- /X Do not check ROM ID
- /K Program all non-critical blocks
- /L Program all ROM Holes
- /ME Program ME Entire Firmware Block

```

FS1:\AfuEfi64\> AfuEfix64.efi BIOS.bin /B /P /N /X /K /L /ME
-----
                AMI Firmware Update Utility v5.09.01.1317
                Copyright (C)2017 American Megatrends Inc. All Rights Reserved.
-----
Reading flash ..... done
- ME Data Size checking . ok
Secure Flash enabled, recalculate ROM size with signature... Enable.
- FFS checksums ..... ok
- Check RomLayout ..... Ok.
Loading capsule to secure memory buffer ... done
Erasing Boot Block ..... done
Updating Boot Block ..... done
Verifying Boot Block ..... done
Erasing Main Block ..... done
Updating Main Block ..... done
Verifying Main Block ..... done
Erasing NVRAM Block ..... done
Updating NVRAM Block ..... done
Verifying NVRAM Block ..... done
Erasing NCB Block ..... done
Updating NCB Block ..... done
Verifying NCB Block ..... done
Erasing RomHole Block ..... done
Updating RomHole Block ..... done
Verifying RomHole Block ..... done
- Update success for FDR
- Update success for GBER |
- Update success for DER. |
- Update success for GBEA... |
- PTT is locked, skip updating.
- Successful Update Recovery Loader to OPRX!!
- Successful Update MFSB!!|
- Successful Update FTFR!!|
- Successful Update MFS, IVB1 and IVB2!!
- Successful Update FLOG and UTOK!!
- ME Entire Image update success !!
WARNING : System must power-off to have the changes take effect!

```

Figure 8-77

 **Note:** After the update is completed, please power off the machine, and then power it on.

8.3.2 Update BIOS in Linux

There are 32bit and 64bit Linux OS afuInx tools. Taking Linux 64bit OS as an example, use the afuInx_64 tool to enter the directory containing afuInx_64 tool. Meanwhile, put the corresponding BIOS bin file into this folder.

When there is no change in ME part, execute the command to update BIOS: ./afuInx_64 BIOS.bin /b /p /n /x /k /l, as shown in the following figure.

```

root@localhost afulnx1# ./afulnx_64 BIOS.bin /B /P /X /N /X /K /L
-----
AMI Firmware Update Utility v5.09.01.1319
Copyright (C)2017 American Megatrends Inc. All Rights Reserved.
-----
Reading flash ..... done
- ME Data Size checking . ok
Secure Flash enabled, recalculate ROM size with signature... Enable.
- FFS checksums ..... ok
Loading capsule to secure memory buffer ... done
Erasing Boot Block ..... done
Updating Boot Block ..... done
Verifying Boot Block ..... done
Erasing Main Block ..... done
Updating Main Block ..... done
Verifying Main Block ..... done
Erasing NURAM Block ..... done
Updating NURAM Block ..... done
Verifying NURAM Block ..... done
Erasing NCB Block ..... done
Updating NCB Block ..... done
Verifying NCB Block ..... done
Erasing RomHole Block ..... done
Updating RomHole Block ..... done
Verifying RomHole Block ..... done

```

Figure 8-78

If there are any changes in ME part, execute the command to update BIOS and ME simultaneously: `./afulnx_64 BIOS.bin /b /p /n /x /k /l /me`, as shown in the following figure.

```

root@localhost afulnx1# ./afulnx_64 BIOS.bin /B /P /X /N /X /K /L /ME
-----
AMI Firmware Update Utility v5.09.01.1319
Copyright (C)2017 American Megatrends Inc. All Rights Reserved.
-----
Reading flash ..... done
- ME Data Size checking . ok
Secure Flash enabled, recalculate ROM size with signature... Enable.
- FFS checksums ..... ok
Loading capsule to secure memory buffer ... done
Erasing Boot Block ..... done
Updating Boot Block ..... done
Verifying Boot Block ..... done
Erasing Main Block ..... done
Updating Main Block ..... done
Verifying Main Block ..... done
Erasing NURAM Block ..... done
Updating NURAM Block ..... done
Verifying NURAM Block ..... done
Erasing NCB Block ..... done
Updating NCB Block ..... done
Verifying NCB Block ..... done
Erasing RomHole Block ..... done
Updating RomHole Block ..... done
Verifying RomHole Block ..... done
- Update success for FDR
- Update success for GBER !
- Update success for DER. !
- Update success for GBEA... !
- PTT is locked, skip updating.
- Update success for MER. - ^
WARNING : System must power-off to have the changes take effect!

```

Figure 8-79

**Notes:**

1. For Linux system, it needs to run the `afulnx_64` tool as root.
2. After the update is completed, please power off the machine, and confirm that there is no residual electricity on the motherboard, and then power it on.

9 BMC Settings

9.1 Introduction

This section introduces the specifications that the management software follows and its main functions.

The Inspur Server Management System is a control unit for server management, which is compatible with the management standard IPMI2.0 specification.

Below are the main functions of the Inspur Server Management System:

- Remote control

Achieves server control via functions such as KVM (Keyboard Video and Mouse), SOL (Serial Over LAN), virtual media, etc.



Note: SOL function must be implemented via third-party tools, such as IPMITool.

- Warning management

Reports warning message in real time, and carries out corresponding solutions according to the information.

- State monitoring

Monitors the running states of all monitoring units in real time.

- Device information management

Provides device version, model and asset information.

- Thermal control

It could adjust fan speed dynamically according to the ambient temperature and workload.

- Supports IPMITool management

Supports the command operation sent by IPMITool.

- Supports WEB interface management

Provides a friendly and visual interface management. Configuration can quickly be completed as well as query tasks, by simply clicking on the interface.

- Supports account centralized management

It is supported to store accounts in the Active Directory server, direct the authentication process to server, and achieve management system login with domain accounts.

9.2 Functional Modules

This chapter introduces the Inspur Server Management System module composition, as well as the functions of these modules.

9.2.1 Module Composition

The Inspur Server Management System is mainly composed of IPMI module, command line module, WEB module, KVM Over IP and virtual media.

- The command line module attains the calling of IPMI module. The user performs the operation on IPMI module via command lines.
- The WEB module attains daily management on server in the form of visual interface via calling IPMI commands, and the WEB module integrates functions of KVM and virtual media.

9.2.2 IPMI Module Introduction

IPMI module attains management of the server system according to the IPMI2.0 standard.

The functions of the IPMI module include:

- System real-time monitoring

Provides the alarm report and alarm indication in the event of fault detection.

- System remote control

Meets the management requirements such as remote power-on/off, and business system reset via command lines and Web.

9.2.3 Command Line Function Introduction

The command line module includes query and setting commands for network, sensor, fan, user management, system and server.

9.2.4 Remote Control Module Introduction

The remote control module includes:

- KVM Over IP: A management method that carries out monitoring and control on remote devices via local video, keyboard and mouse to the client, enabling the operation of remote devices in real-time.
- Virtual Media: A method of providing remote access on local media (CD-ROM, floppy drive or CD/floppy disk iso file) in the form of virtual CD driver and floppy drive on server via the internet.

To use the remote control function, the client should be equipped with appropriate browser

and Java runtime environment.



Note:

If the Java runtime environment does not meet the requirements, you can download it at <http://www.oracle.com/technetwork/java/javase/downloads/index.html>.

9.3 Web Interface Introduction

This section introduces the Web interface of the management system, as well as operation steps to login to the Web interface.

- Login Web interface: Introduces the method to login the Web interface.
- Web interface introduction: Introduces the Web interface layout.

9.3.1 Web Interface Login

This guide introduces the operation steps to login to the Web management interface, taking the Windows Operating System and the Firefox browser as an example.



Note: When carrying out interface operation via Web, a maximum of 20 users can be logged in at the same time.

Step 1: Ensure the management network ports on the client and server are connected to the internet.

Step 2: Open the browser, and enter “http://ipaddress” in the address bar (The default login mode is https, and the safe operation configuration is needed).

Step 3: The login interface should appear as shown below:

1. Enter the user name and password.



Note: The system provides a default user “admin” in administrator user group, and the default password is “admin”.

2. Click “Login” to enter the management interface.

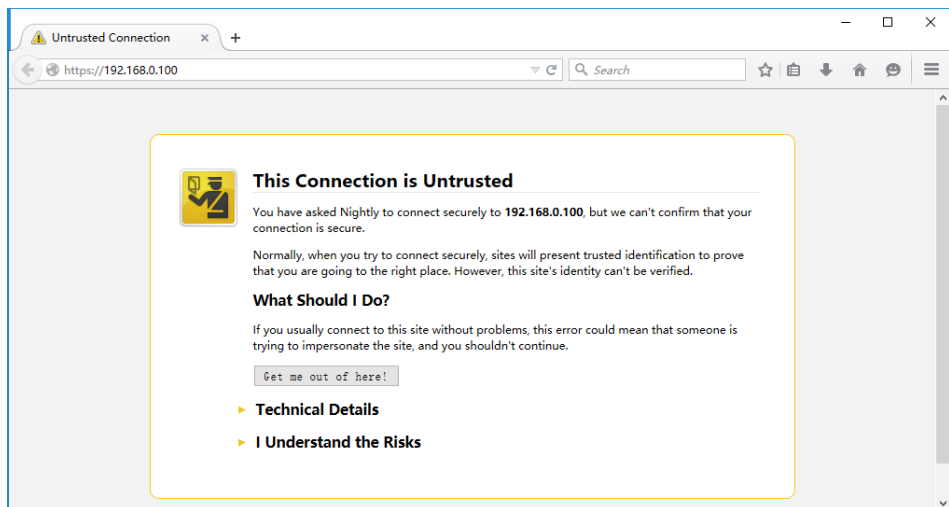

Figure 9-1

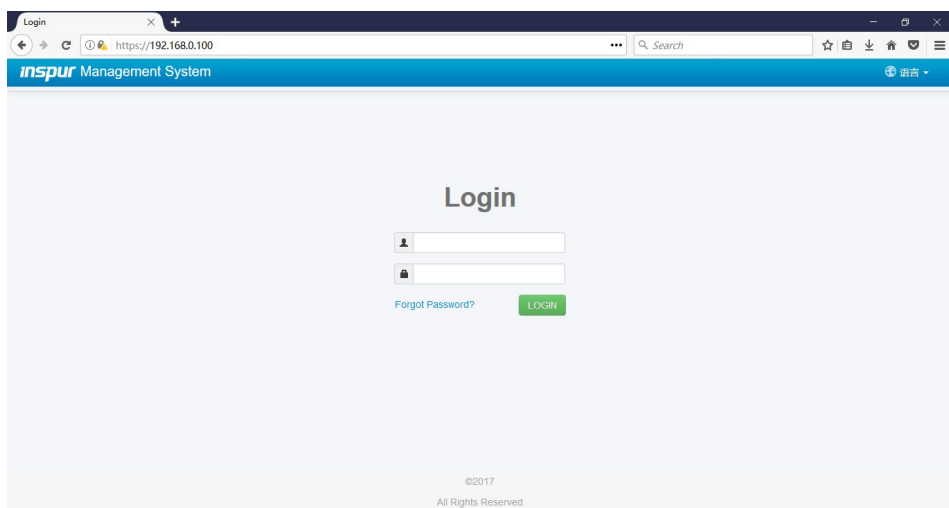



Figure 9-2

9.3.2 Web Interface Introduction

The Web interface helps users accomplish server management. The Web interface also has a help function so users can click the help button  in the case that they may need it.

The Web interface is divided into several parts, as shown in the following figure.

inspur Management System admin Overview Refresh UID:ON POWER.ON 语言 Help Logout

- Information
- Storage
- Remote Control
- Power and Fan
- BMC Settings
- Logs
- Fault Diagnosis
- Administration

General Information

System Running State

Current Power Status	●
UID State	●
CPU	●
Memory	●
Hard Disk	●
Fan	✖
Fan redundancy	⚠
Power Supply Units	●
Power redundancy	✖
Voltage	●
Temperature	●
ME	●

Quick Launch Tasks

- Console Redirection
- Power Control
- Users
- Network
- Hardware Monitor
- Firmware Update

Active Session

User Type	User Name	User Privilege	IP Address
HTTPS	admin	Administrator	192.168.0.20

BMC Information

Lan Interface	● Shared ● Dedicated
MAC Address	6C:92:BF:58:F3:DE
Network Mode	DHCP
IPv4 Address	0.0.0.0
Server Running Time	0 Day, 0 Hour

Server Information

Chassis Type	Rack Mount Chassis
Product Name	NF5280M5
Manufacture Name	Inspur
Product Serial Number	0
Asset Tag	NULL
UUID	58b7926c-def3-03df-b211-d21da0e5c119

FW Version Information

BMC	3.2.0 (2017-08-19 17:36:38)
BIOS	3.0.1
ME	0A:4.0.3.219
PSU_0	N/A
PSU_1	1.000
CPU0_PVCCIN_VR	YZMB-00882-U78-V2.0
CPU0_PVCCIO_VR	YZMB-00882-U29-V2.0
CPU0_PVDDQ1_VR	YZMB-00882-U27-V2.0
CPU0_PVDDQ2_VR	YZMB-00882-U26-V2.0
CPU1_PVCCIN_VR	YZMB-00882-U86-V2.0
CPU1_PVCCIO_VR	YZMB-00882-U161-V2.0
CPU1_PVDDQ1_VR	YZMB-00882-U28-V2.0
CPU1_PVDDQ2_VR	YZMB-00882-U162-V2.0
CPLD	N/A
Front_HDD_CPLD0	N/A
Front_HDD_CPLD1	N/A
Front_HDD_CPLD2	N/A
Rear_HDD_CPLD0	N/A
Rear_HDD_CPLD1	N/A
Rear_HDD_CPLD2	N/A
Rear_HDD_CPLD3	N/A
TPM	N/A

Recent System Event Log [More]

Event ID	Time Stamp	Severity	Sensor Name	Sensor Type	Description
21	08/21/2017 12:10:07	✖	FAN2_R_Speed	Fan	Lower Critical - Going Low - Asserted
20	08/21/2017 12:10:07	✖	FAN2_F_Speed	Fan	Lower Critical - Going Low - Asserted
19	08/21/2017 12:10:07	✖	FAN1_R_Speed	Fan	Lower Critical - Going Low - Asserted
18	08/21/2017 12:10:07	✖	FAN1_F_Speed	Fan	Lower Critical - Going Low - Asserted
17	08/21/2017 12:10:07	✖	FAN0_R_Speed	Fan	Lower Critical - Going Low - Asserted
16	08/21/2017 12:10:07	✖	FAN0_F_Speed	Fan	Lower Critical - Going Low - Asserted
15	08/21/2017 12:10:04	●	SYS_FW_Progress	BIOS POST Progress	Progress-PCI resource configuration - Asserted
14	08/21/2017 12:10:04	●	SYS_FW_Progress	BIOS POST Progress	Progress-PCI resource configuration - Asserted
13	08/21/2017 12:10:04	●	SYS_FW_Progress	BIOS POST Progress	Progress-PCI resource configuration - Asserted
12	08/21/2017 12:10:04	✖	FAN2_Present	Fan	Device Removed / Device Absent - Asserted

Note:
 ● Normal ● Information ⚠ Warning ✖ Critical ● Power On/Present/Redundant ● Power Off/Absent/N/A/No-Redundant ● Not Support
 ©2017
 All Rights Reserved

Figure 9-3

- The name of the Web interface is displayed on top left of the interface.

- The meanings of all buttons on top right of the interface:

- ◇ Overview Click on the Overview button, to return to the overview page.

- ◇ Refresh Click on the Refresh button, to refresh the page.

- ◇ UID:ON Click on the UID button, to turn on/off the UID LED.

- ◇ POWER.ON Click on the Power button, to turn on/off the server.

- ◇ Language Click on the Language button, to change the language (which supports

Chinese and English).

◇  Click on the Help button to query help information on the corresponding page.

◇  Click on the Logout button, to return to the login page.

- The navigation tree is on the left. Via the nodes on the tree, you can select different functional interfaces. The following functions are included:

- Information
- Storage
- Remote control
- Power and fan
- BMC settings
- Logs
- Fault diagnosis
- Administration

For detailed introduction on all functions, please refer to the following chapters.

- Specific operation interface is on the right of the interface.

9.3.3 Overview

Click on Overview to open the “General Information” interface, as shown below.

The screenshot displays the Inspur Management System interface. The top navigation bar includes 'inspur Management System', 'admin', 'OverView', 'Refresh', 'UID: ON', 'POWER: ON', '语言', 'Help', and 'Logout'. The left sidebar contains a navigation tree with 'Information' selected. The main content area is divided into several sections:

- General Information**: A 'System Running State' table showing various system metrics with status indicators (green for OK, red for error, yellow for warning). Metrics include Current Power Status, UID State, CPU, Memory, Hard Disk, Fan, Fan redundancy, Power Supply Units, Power redundancy, Voltage, Temperature, and ME.
- BMC Information**: A table showing network settings such as Lan Interface (Shared/Dedicated), MAC Address, Network Mode, IPv4 Address, and Server Running Time.
- Server Information**: A table providing details about the server hardware, including Chassis Type, Product Name, Manufacture Name, Product Serial Number, Asset Tag, and UID.
- FW Version Information**: A table listing various firmware versions for components like BMC, BIOS, ME, PSU, CPU, CPLD, and HDD.
- Quick Launch Tasks**: A grid of icons for Console Redirection, Power Control, Users, Network, Hardware Monitor, and Firmware Update.
- Active Session**: A table showing active sessions with columns for User Type, User Name, User Privilege, and IP Address.
- Recent System Event Log**: A table with columns for Event ID, Time Stamp, Severity, Sensor Name, Sensor Type, and Description. It lists events related to fan speeds and BIOS progress.

A legend at the bottom identifies the severity levels: Normal (green), Information (blue), Warning (yellow), Critical (red), Power On/Present/Redundant (grey), Power Off/Absent/N/A/No-Redundant (grey), and Not Support (grey).

Figure 9-4

9.3.4 Information

Select “Information” on the navigation tree. It contains the interfaces of system information, BIOS setup options and history record, as shown in the following figures below.

- System information: Displays system configuration information, including CPU, memory, PCIE device, network, hard disk, power supply unit, fan, temperature and voltage information.
- BIOS setup options: Displays the key BIOS setup options information.
- History record: Displays the history information of inlet air temperature and total power.

System Information

System Information									
CPU									
No.	Processor Name	Processor Status	Processor Speed	Core	TDP(W)	L1 Cache(KB)	L2 Cache(KB)	L3 Cache(KB)	
CPU0	Intel(R) Xeon(R) Gold 6130T CPU @ 2.10GHz	●	2100	16/16	125	64	1024	22528	
CPU1	N/A	●	N/A	N/A	N/A	N/A	N/A	N/A	

Figure 9-5

BIOS Setup Options

Advanced	
Setup Option	Setup Option Value
Security Device Support	Enable
COM0 Console Redirection	Disable
Above 4G Decoding	Enable
SR-IOV Support	Enable
Network Stack	Enable
Ipv4 PXE Support	Enable
Ipv6 PXE Support	Disable
CSM Support	Enable
Boot Mode	UEFI
Option ROM execution Network	UEFI
Option ROM execution Storage	UEFI
Option ROM execution Video OPROM Policy	UEFI
Option ROM execution Other PCI devices	UEFI

Figure 9-6

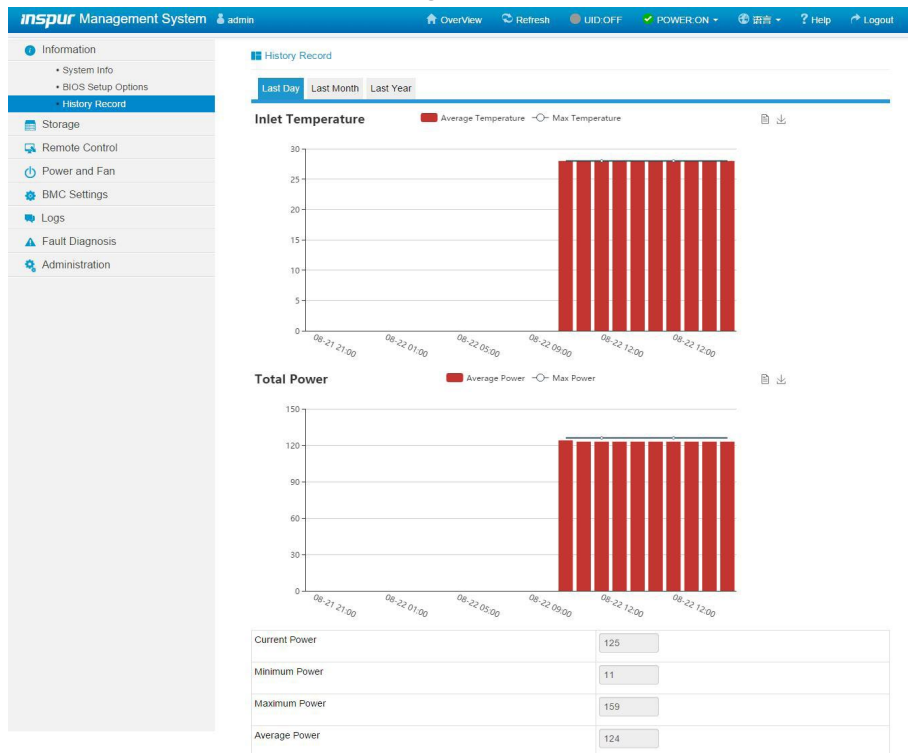

Figure 9-7

9.4 Storage

Select “Storage” on the navigation tree to open the storage interface. This interface contains controller, physical drives, logical drives and enclosure information, as shown in the following figures.

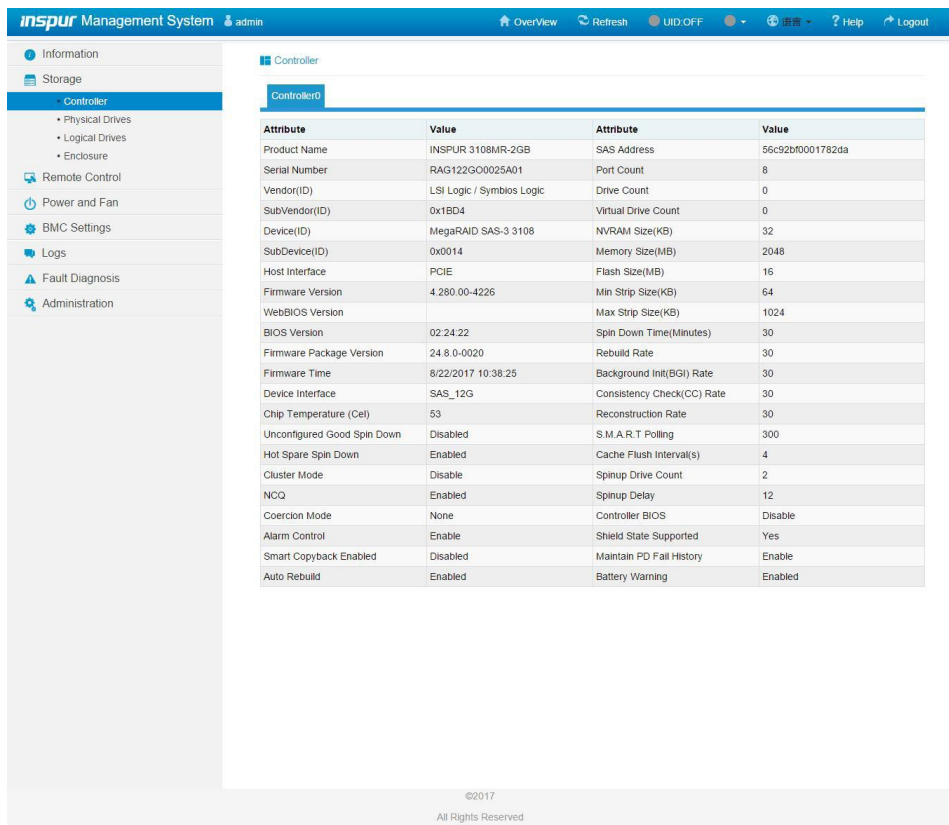

Figure 9-8

9.5 Remote Control

Select “Remote Control” on the navigation tree to open the remote control interface, which contains the interfaces of console redirection, locate server, remote session, virtual media and mouse mode settings, as shown in the following figures.

- Console redirection (KVM): The KVM console window will pop up. Java KVM and HTML5 KVM are supported.
- Server location: To turn on/off the system ID LED.
- Configure remote session: To set the KVM session encryption, media encryption and virtual media connection methods.
- Virtual media devices: To set the quantity of virtual media (floppy devices, CD/DVD

devices and hard disk drives, etc.).

- Mouse mode settings: To set the mouse working mode for KVM remote console.

■ Console Redirection

Console Redirection	
Control console redirection	Launch KVM HTML5 Viewer
Control console redirection	Launch KVM Java Viewer

Figure 9-9

■ Server Location

Server Location	
System ID LED Status	<input type="radio"/>
System ID LED Light Time	<input checked="" type="radio"/> All the time <input type="radio"/> 10s <input type="radio"/> 20s <input type="radio"/> 60s <input type="radio"/> Other <input type="text"/> s
System ID LED Operation	<input type="button" value="Turn On Led"/> <input type="button" value="Turn Off Led"/>

Figure 9-10

■ Configure Remote Session

Configure Remote Session	
Encrypt H5Viewer KVM packets	<input type="checkbox"/> Enable
Keyboard Language	Auto Detect (AD) <input type="button" value="v"/>
Virtual Media Attach Mode	Auto Attach <input type="button" value="v"/>
Retry Count	3 <input type="button" value="v"/>
Retry Time Interval(Seconds)	22 <input type="button" value="v"/>
Server Monitor OFF Feature Status	<input checked="" type="checkbox"/> Enable
Automatically OFF Server Monitor, When KVM Launches	<input type="checkbox"/> Enable

Figure 9-11

■ Virtual Media Devices

Virtual Media Setup **Virtual Media Instance**

Virtual Media Instance	
Floppy devices	1 <input type="button" value="v"/>
CD/DVD devices	1 <input type="button" value="v"/>
Harddisk devices	1 <input type="button" value="v"/>
Remote KVM Floppy devices	1 <input type="button" value="v"/>
Remote KVM CD/DVD devices	1 <input type="button" value="v"/>
Remote KVM Hard disk devices	1 <input type="button" value="v"/>
SD Media Support	<input type="checkbox"/> Enable
Encrypt Media Redirection Packets	<input type="checkbox"/> Enable
Power Save Mode	<input type="checkbox"/> Enable

Figure 9-12

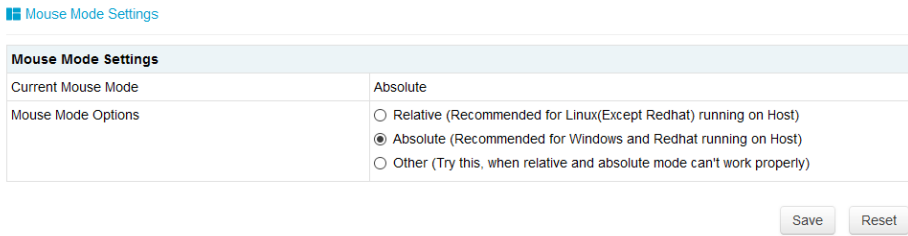

Figure 9-13

9.6 Power and Fan

Select “Power and Fan” on the navigation tree to open the power supply and fan interface. It contains the interfaces of power supply monitor, power supply configure, server power control, power peak and fan speed control, as shown in the following figures.

- Power supply monitor: Contains PSU present state, alert, temperature, input power, output power, input voltage, output voltage, input current, output current and firmware version information.
- Power supply configure: Contains PSU present state, current state and A/S mode switch function.
- Fan speed control: Contains fan status, current speed and speed control function.



Note: Fan speed control contains the following speed levels:

- Low: About 20% duty ratio
- Medium: About 50% duty ratio
- High: About 75% duty ratio
- Full: 100% duty ratio

- Server power control: Contains the server’s power on/off and reset, as well as the power policy on AC power loss.
- Power peak settings: To enable or disable the power peak, and set the maximum random time.

Power Supply Monitor

No.	Present	Alert	Temp(C)	Pin(W)	Pout(W)	Vin(V)	Vout(V)	Iin(A)	Iout(A)	FW Version
0	●	NO WARNING	26	129	103	219	12.15	0.64	8.46	1.000
1	●	NO WARNING	0	0	0	0	0	0	0	N/A

Note:

● Present ● Absent

Figure 9-14

Power Supply Configure

No.	Present	Current State	A/S Switch
0	●	Normal	<input type="button" value="Switch to Standby"/>
1	●	N/A	<input type="button" value="Switch to Standby"/>

Note:

● Present ● Absent

Figure 9-15

Fan Speed Control

Manual Fan Control Auto Fan Control

No.	Present	Status	Current speed(rpm)	Duty Ratio(%)	Speed control
FAN_0_Front	●	●	0	0	<input type="button" value="Low(20%)"/> <input type="button" value="Medium(50%)"/> <input type="button" value="High(75%)"/> <input type="button" value="Full(100%)"/>
FAN_0_Rear	●	●	0	0	<input type="button" value="Low(20%)"/> <input type="button" value="Medium(50%)"/> <input type="button" value="High(75%)"/> <input type="button" value="Full(100%)"/>
FAN_1_Front	●	●	0	0	<input type="button" value="Low(20%)"/> <input type="button" value="Medium(50%)"/> <input type="button" value="High(75%)"/> <input type="button" value="Full(100%)"/>
FAN_1_Rear	●	●	0	0	<input type="button" value="Low(20%)"/> <input type="button" value="Medium(50%)"/> <input type="button" value="High(75%)"/> <input type="button" value="Full(100%)"/>
FAN_2_Front	●	●	0	0	<input type="button" value="Low(20%)"/> <input type="button" value="Medium(50%)"/> <input type="button" value="High(75%)"/> <input type="button" value="Full(100%)"/>
FAN_2_Rear	●	●	0	0	<input type="button" value="Low(20%)"/> <input type="button" value="Medium(50%)"/> <input type="button" value="High(75%)"/> <input type="button" value="Full(100%)"/>
FAN_3_Front	●	✔	5280	24	<input type="button" value="Low(20%)"/> <input type="button" value="Medium(50%)"/> <input type="button" value="High(75%)"/> <input type="button" value="Full(100%)"/>
FAN_3_Rear	●	✔	4416	24	<input type="button" value="Low(20%)"/> <input type="button" value="Medium(50%)"/> <input type="button" value="High(75%)"/> <input type="button" value="Full(100%)"/>

Note:

✔ Normal ✘ Critical ● N/A

Figure 9-16

Server Power Control

Virtual Power Button

Power Restore Setting

Server Power Control

Current Power Status ● ON

Control Options

- Power On
- Force Power Off
- Power Cycle
- Hard Reset
- Soft Shutdown

Figure 9-17

Server Power Control

Virtual Power Button

Power Restore Setting

Power Policy

Current Power Status ● ON

Power Policy Options

- Always Power On
- Always Power Off
- Restore Last Power State

Figure 9-18

9.7 BMC Settings

Select “BMC Settings” on the navigation tree to open the BMC Settings interface. It contains the interfaces of BMC network, services, NTP, SMTP, alerts, threshold, access control, BMC share NIC switch and BIOS boot options, as shown in the following figures.

- **BMC network management:** Contains BMC network (static IP and DHCP), DNS settings and network interface bonding and network link information.
- **Services:** To configure the BMC’s Web service, KVM service, ssh service, telnet service, etc.
- **NTP settings:** To set the BMC time, which has two methods:
 - Synchronize from NTP server.
 - Set time manually.
- **SMTP settings:** To set the SMTP server information related to alert.
- **Alert settings:** To set the alert event filtering and alert targets of BMC management module.
- **Access control:** To set IP address fields accessible to BMC.
- **BMC share NIC switch:** Contains NCSI type switch, NCSI mode switch and channel switch.
- **BIOS boot options:** To set the boot option after BIOS reset.

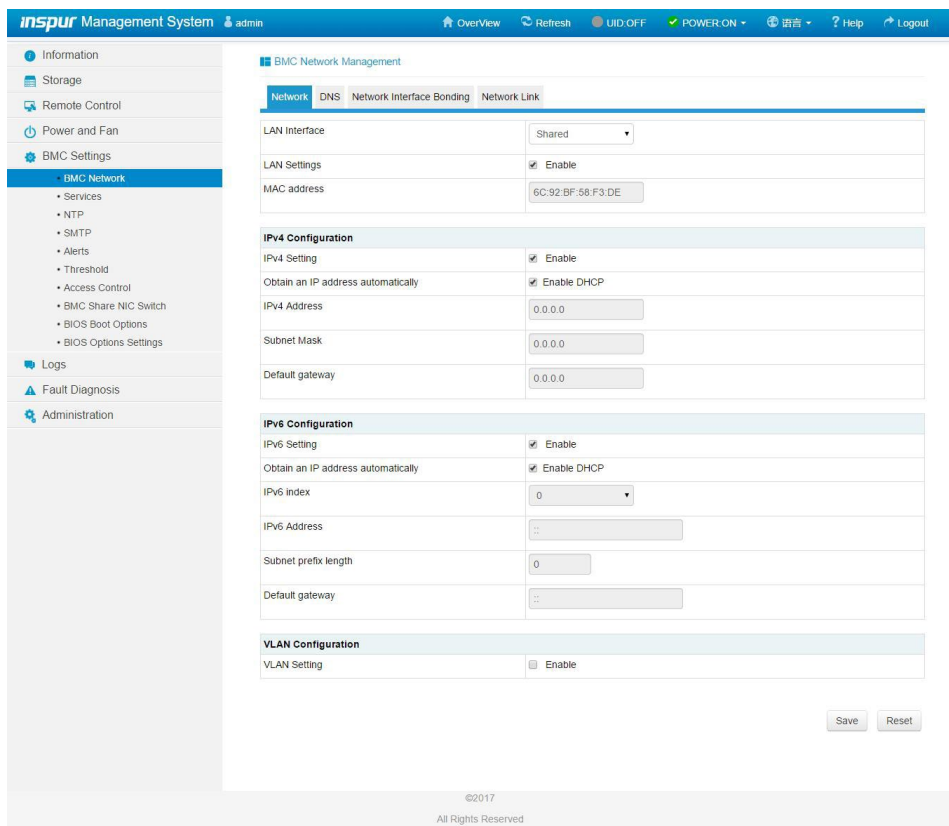

Figure 9-19

Services

#	Service Name	Current State	Interfaces	Nonsecure Port	Secure Port	Timeout(s)	Maximum Sessions	Active Sessions
1	web	Active	both	80	443	1800	20	2
2	kvm	Active	both	7578	7582	1800	4	0
3	cd-media	Active	both	5120	5124	N/A	4	0
4	fd-media	Active	both	5122	5126	N/A	4	0
5	hd-media	Active	both	5123	5127	N/A	4	0
6	ssh	Active	N/A	N/A	22	600	N/A	0
7	telnet	Inactive	N/A	23	N/A	600	N/A	0
8	soissh	Inactive	N/A	52123	N/A	60	N/A	0

Figure 9-20

NTP Settings

NTP Settings

Date: 8 Month 22 Day 2017 Year

Time: 10 57 56 hh:mm:ss

UTC TimeZone: (GMT+08:00)Beijing_Chongqi

NTP Server1: pool.ntp.org

NTP Server2: time.nist.gov

NTP Server3: time.nist.gov

Automatically synchronize Date & Time with NTP Server

Refresh Save Reset

Figure 9-21

SMTP Settings

LAN Channel: Dedicated

Sender Email: user@bmc.com

Primary SMTP Server

SMTP Support: Enable

SMTP Server Names: bmc.com

SMTP Server IP Address: 192.168.0.20

Port: 25

SMTP Server Authentication:

Username: user

Password:

Figure 9-22

Alert Settings

SNMP Trap Configure

Trap Version	v1
Event Severity	All
Community	public
Username	
Engine ID(Hex)	
Authentication and password	NONE
Privacy and password	NONE
System Name	
System ID	
Host Location	
Contact	
Host OS	

Event Filter

Sensor Type	All Sensors
Sensor Name	All Sensors

Alert Policy Configure

No.	Enable	LAN Channel	Alert Type	Destination	Action

©2017 All Rights Reserved

Figure 9-23

Access Control

Note:

- Operate host's IP or MAC must be added first, when add IP access policies.
- Operate host's IP or MAC must be deleted last, when delete IP access policies.

Access Control

Add Accept Entry

IP: 192.168.0.40 To 192.168.0.50
 MAC:
 Rule: Allow
 Enable Timeout:
 Start Date:
 Stop Date:
 ADD

Current Accept Entry List

IP:192.168.0.10 - 192.168.0.30	DELETE
Rule: Allow	
Enable Timeout: Enable	
Start Date: 2017-8-21 10:26:00	
Stop Date: 2017-8-25 10:26:00	

©2017 All Rights Reserved

Figure 9-24

■ BMC Share NIC Switch

NCSI Type	
NCSI Type	PHY
Network Interface Switch	
NCSI Mode	<input checked="" type="radio"/> Auto Failover <input type="radio"/> Manual Switch
Share NIC	eth0
Channel Number	3
<input type="button" value="Save"/> <input type="button" value="Reset"/>	

Figure 9-25

■ BIOS Boot Options

Boot Options

BIOS Boot Options	
Timeliness	<input checked="" type="radio"/> Apply to next boot only <input type="radio"/> Apply to be persistent for all future boots
Boot Options	<input checked="" type="radio"/> No override <input type="radio"/> Force PXE <input type="radio"/> Force boot from default Hard-drive <input type="radio"/> Force boot from default CD/DVD <input type="radio"/> Force boot into BIOS Setup
<input type="button" value="Perform Action"/>	

Figure 9-26

9.8 Logs

Select “Logs” on the navigation tree to open the related log interface. It contains the interfaces of system event log, BMC system audit log, black box log, event log setting and BMC system audit log setting, as shown in the following figures.

- System event log: Displays various event logs generated by the server.
- BMC system audit log: Displays system logs and audit logs of BMC.
- Black box log: Used to import fault logs.
- Event log setting: To set the BMC log storage policy:
 - Linear strategy: To clear all logs after log storage is full and record again.
 - Circular strategy: To record circularly after log record is full.
- System and audit log settings: To set the log type, file size and other information of BMC system audit logs.

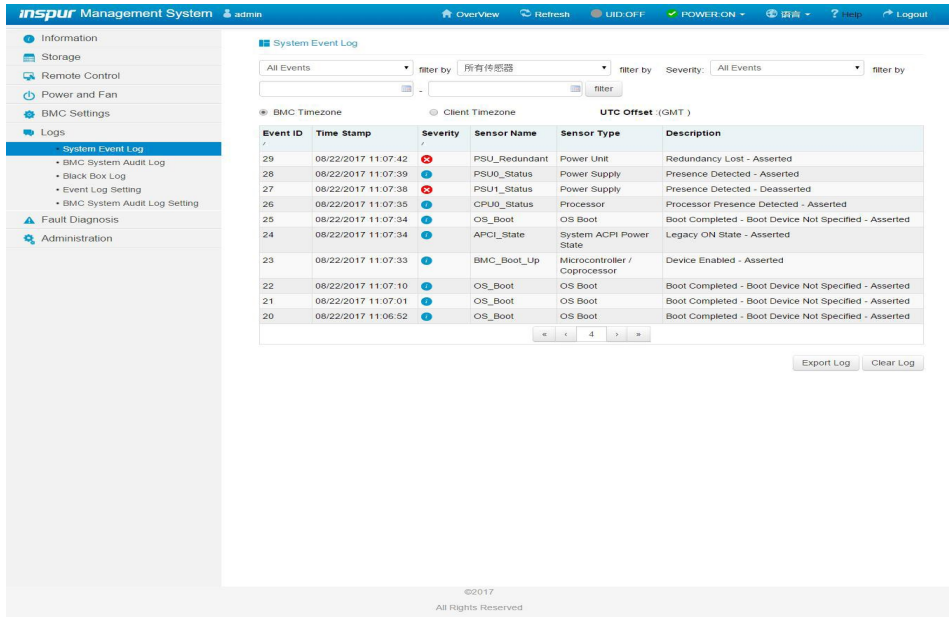

Figure 9-27

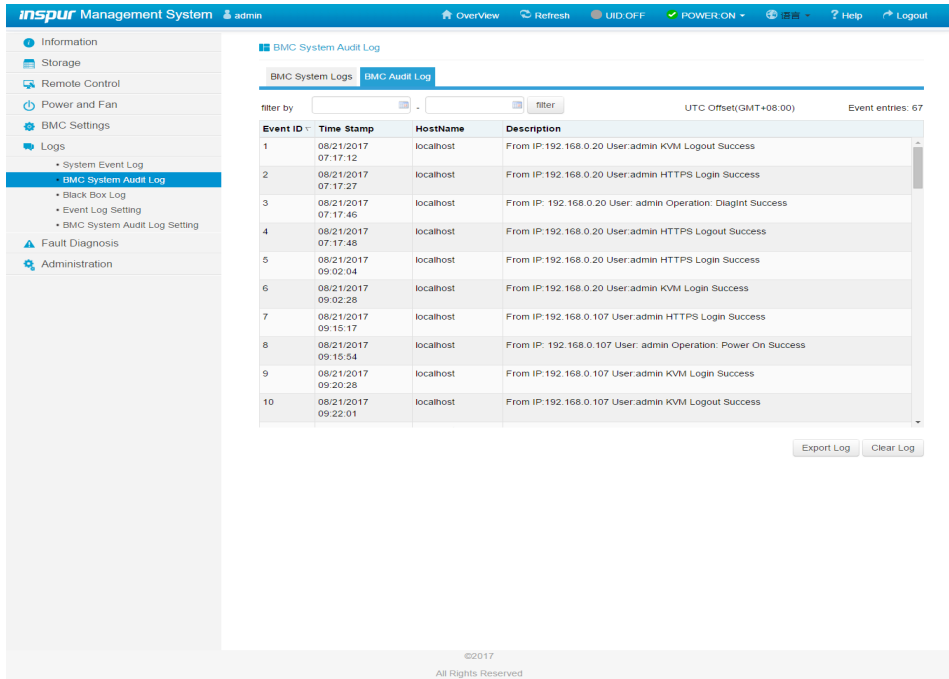

Figure 9-28

■ Black Box Log

Black Box Log

Log Selection	blackbox.log ▼
---------------	----------------

Figure 9-29

■ Event Log Setting

Event Log Setting

Current Event Log Policy	Circular Policy
System Event Log Policy Options	<input type="radio"/> Linear Policy <input checked="" type="radio"/> Circular Policy

Figure 9-30

■ System and Audit Log Settings

System and Audit Log Settings

System Log	<input checked="" type="checkbox"/> Enable
Log Type	<input checked="" type="radio"/> Local Log <input type="radio"/> Remote Log
File Size (in bytes)	<input type="text" value="50000"/>
Rotate Count	<input type="text" value="0"/>
Server Address	<input type="text"/>
Server Port	<input type="text" value="0"/>
Audit Log	<input checked="" type="checkbox"/> Enable

Figure 9-31

9.9 Fault Diagnosis

Select “Fault Diagnosis” on the navigation tree to open the fault diagnosis interface. It contains the interfaces of BMC self-inspection result, BMC recovery, capture screen and host POST code, as shown in the following figures.

- BMC self-inspection result: To view the BMC self-inspection result.
- BMC recovery: Contains two functions of BMC warm reset and KVM service restart.
- Capture screen: Used to record the information on the last screen at system crash.



Note: To support BSOD (Blue Screen Of Death) screen capturing, server OS should be Windows 2012R2 and above.

- Host POST code: Displays POST code during system startup.

BMC Self-inspection Result

BMC Self-inspection Result	
Current Self-inspection Result	55 00

Figure 9-32

BMC Recovery

BMC Recovery	
BMC Recovery Options	<input checked="" type="radio"/> BMC Warm Reset <input type="radio"/> KVM Service Restart
<input type="button" value="Perform Action"/>	

Figure 9-33

inspur Management System admin Overview Refresh UID OFF POWER ON 语言 ? Help Logout

- Information
- Storage
- Remote Control
- Power and Fan
- BMC Settings
- Logs
- Fault Diagnosis
 - BMC Self-inspection Result
 - BMC Recovery
 - Capture Screen**
 - Host POST Code
- Administration

Capture Screen

Auto Capture Manual Capture

- BMC will record monitor screen information after server power reset or power off.
- Support BSOD(Blue Screen Of Death) screen capturing, server OS should be Windows 2012R2 and above.
- The three pictures in left side display screen with latest power reset or power off (or BSOD) , captured time displayed below.
- Click pictures in left side, clear picture will be displayed in right side

Auto Capture Funtion :
 Enabled Disabled



2017-08-23 01:05:40



2017-08-23 01:05:45



2017-08-23 01:05:47

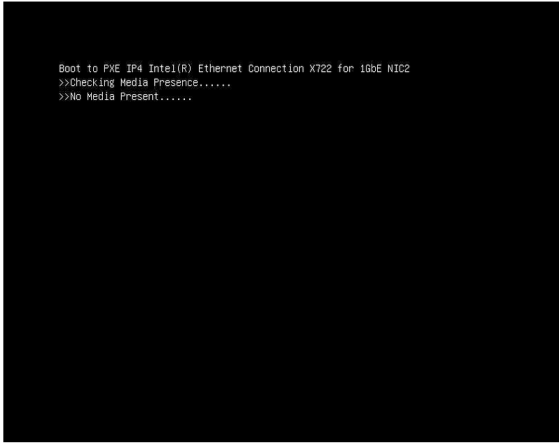

©2017 All Rights Reserved

Figure 9-34

Host POST Code

Host POST Code	
Current Power Status	<input checked="" type="radio"/> ON
Current POST Code	00
POST Code Records	31 a1 a3 a3 a7 a9 aa ab af 32 b0 b0 b1 b1 af 00

Figure 9-35

9.10 Administration

Select “Administration” on the navigation tree to open the administration interface. It contains the interfaces of user administration, security, dual image configuration, dual firmware update, BIOS firmware update and restore factory defaults, as shown in the following figures.

- User administration: To add, delete or modify users via BMC Web interface.
- Security: To configure LDAP and AD servers via BMC Web interface.
- Dual image configuration: To configure the boot options in dual image mode via BMC Web interface.
- Dual firmware update: To update BMC FW via BMC Web interface.
- BIOS firmware update: To update BIOS FW via BMC Web interface.
- Restore factory defaults: To restore BMC’s configuration to factory state.

The screenshot displays the 'inspur Management System' interface. The left sidebar contains a navigation tree with 'Administration' selected. The main area is titled 'User Administration' and includes tabs for 'System Administrator', 'Local Users', and 'Directory Group'. The 'Local Users' tab is active, showing 'Local User Password Rules' with a 'Password Check' option set to 'Disabled'. Below this are sections for 'Add Group', 'Modify Group', and 'Delete Group', each with a form to configure group details like name and privilege. At the bottom, there is a table listing users with columns for UserID, Username, User Group, User Access, Network Privilege, and Email ID. The table shows 16 rows, with the first row having UserID 1 and Username 'admin'.

UserID	Username	User Group	User Access	Network Privilege	Email ID
1	admin	Administrator	Enabled	administrator	
2	~	~	~	~	~
3	~	~	~	~	~
4	~	~	~	~	~
5	~	~	~	~	~
6	~	~	~	~	~
7	~	~	~	~	~
8	~	~	~	~	~
9	~	~	~	~	~
10	~	~	~	~	~
11	~	~	~	~	~
12	~	~	~	~	~
13	~	~	~	~	~
14	~	~	~	~	~
15	~	~	~	~	~
16	~	~	~	~	~

Figure 9-36

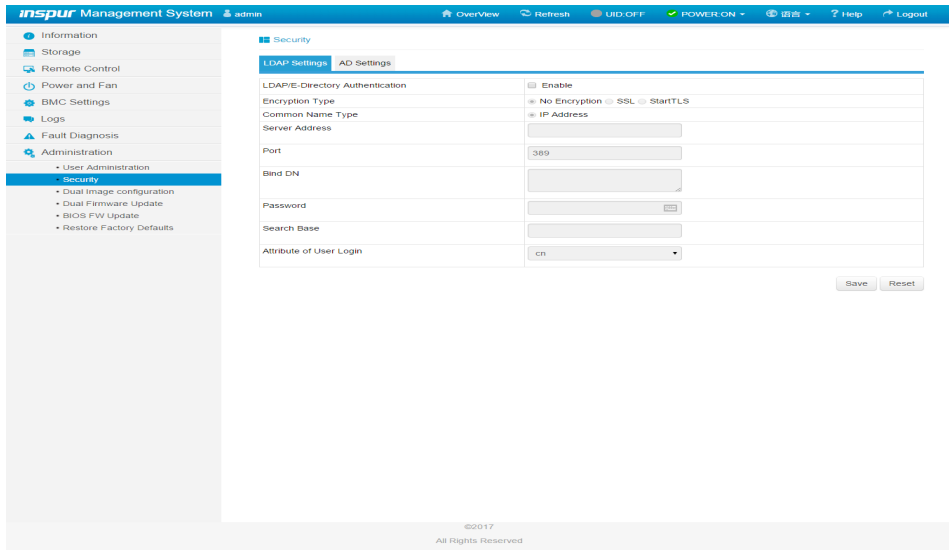

Figure 9-37

Dual Image configuration

IMAGE-1	
Firmware Version	3.2.0
State	Active
<input checked="" type="radio"/> Image to be booted from upon reset	

IMAGE-2	
Firmware Version	3.2.0
State	stand-by
<input type="radio"/> Image to be booted from upon reset	

- Higher firmware version
- Lower firmware version
- Newest updated firmware
- Not newest updated firmware

Figure 9-38

inspur Management System admin Overview Refresh UID: OFF POWER: ON 语言 ? Help Logout

- Information
- Storage
- Remote Control
- Power and Fan
- BMC Settings**
- Logs
- Fault Diagnosis
- Administration
 - User Administration
 - Security
 - Dual Image configuration
 - Dual Firmware Update**
 - BIOS FW Update
 - Restore Factory Defaults

BMC Firmware Update

Please note:

- After entering update mode widgets, other web pages and services will not work. All open widgets will be closed automatically. If upgrade process is cancelled after clicking the button of 'Start firmware update', the device will reset.
- Click 'Preserve all configuration' will preserve all the configuration settings during the firmware update.
- This section lists the configuration items. Items that configured as 'Preserve' will be preserved during restore factory default configuration. Click 'Preserve Configuration' to modify the preserve configuration items.
- Click 'Enter Firmware Update Mode' to update firmware.

Current Active Image IMAGE-1

Image to be Updated

Preserve all configuration

NO.	Preserve Settings	Update Policy
1	SDR	Overwrite
2	SEL	Overwrite
3	IPMI	Overwrite
4	PEF	Overwrite
5	SOL	Overwrite
6	SMTP	Overwrite
7	User	Overwrite
8	DCMI	Overwrite
9	Network	Overwrite
10	NTP	Overwrite
11	SNMP	Overwrite
12	SSH	Overwrite
13	KVM	Overwrite
14	Authentication	Overwrite
15	Syslog	Overwrite
16	Hostname	Overwrite

©2017
All Rights Reserved

Figure 9-39

BIOS Firmware Update

Please note:

- You'd better **Power Off** the system if you want to do BIOS Update.
- BIOS NVRAM will be cleared and BIOS will become default after BIOS flashed.
- After BIOS+ME flashed, we recommend to **AC Power Off and On** to enable NEW ME.

1. Please click the button to enter firmware update mode.

BIOS Bin File Type

Options to be preserved

- BIOS Setup Options
- PHY Image
- PHY MAC

Figure 9-40

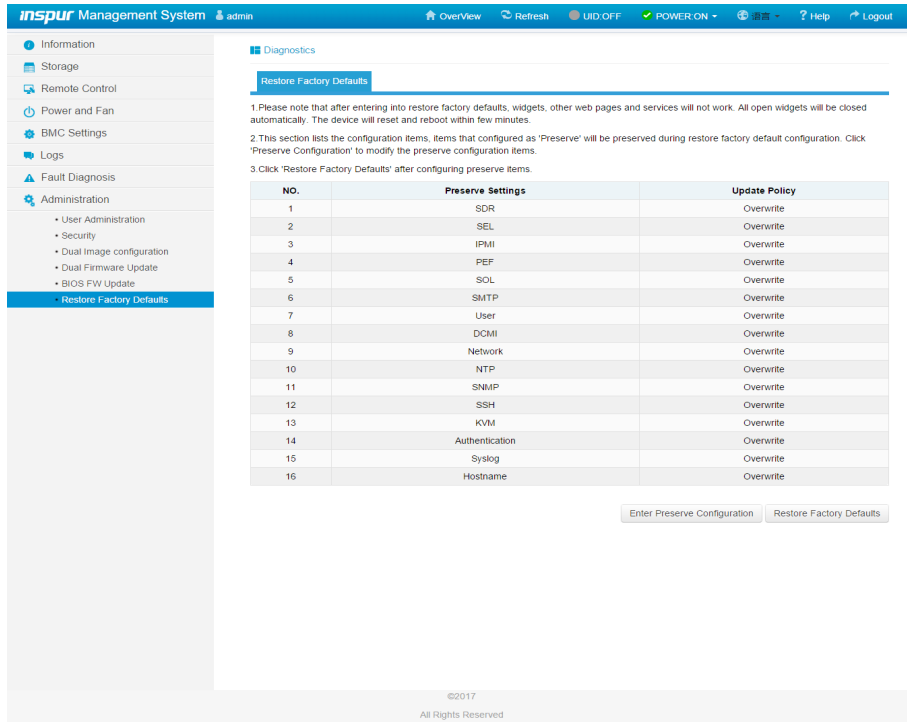

Figure 9-41

9.11 Command Line Function Introduction

This chapter introduces Web interface of the management system, as well as operation steps to login to the Web interface.

- Command line login

Introduces the methods of command line login.

- Command line function introduction

Introduces the command line functions.

9.11.1 Command Line Login

Login to BMC Command line through ssh. After login, enter the command line interface:

```

Connecting to 192.168.0.100:22...
Connection established.
To escape to local shell, press 'Ctrl+Alt+'.

Executing [~/usr/local/bin/smashclp]

>> smashclp <<
////////////////////////////////////
smashclp cli tool version 1.0
Enter 'help' for a list of built-in commands
////////////////////////////////////

/smashclp>

```

Figure 9-42

Enter help to view online help:

```

/smashclp> help
Built-in command:
-----
ipconfig:  get or set network parameters, please enter <ipconfig --help> for more information
sensor :   get or set sensor parameters, please enter <sensor --help> for more information
fru       :   get or set fru parameters, please enter <fru --help> for more information
chassis  :   get or set chassis parameters, please enter <chassis --help> for more information
user     :   get or set user parameters, please enter <user --help> for more information
mc       :   get or set mc parameters, please enter <mc --help> for more information
fan      :   get or set fan parameters, please enter <fan --help> for more information
psu      :   get or set psu parameters, please enter <psu --help> for more information
password :   change root password
update   :   firmware update operator, please enter <update --help> for more information
diagnose :   BMC diagnose function, please enter <diagnose --help> for more information
sol      :   sol (text redirection) function, please enter <sol --help> for more information
id       :   id get identify function, please enter <id --help> for more information
diaglog  :   BMC diaglog function, please enter <diaglog --help> for more information
register :   BMC registerinfo function, please enter <register --help> for more information
exit     :   exit the command line
/smashclp>

```

Figure 9-43

9.11.2 Command Line Function Introduction

9.11.2.1 Get and Set Network Information

Via ipconfig command, get and set BMC's network information:

```

/smashclp> ipconfig --help
ipconfig commands:
  ipconfig <option1> [<option2> [<parameter2>]] [<option3> [<parameter3>]...] [interface]
  option1:
    --help      show help information
    ?          show help information
    --get       get network information
    for example : ipconfig --get [<option2>] [<option3>...] [interface]
    --set       set network information
    for example : ipconfig --set <option2> <parameter2> [<option3> <parameter3>...] <interface>
  option2..n:
    --ipsrc <source>
    static = address manually configured to be static
    dhcp   = address obtained by BMC running dhcp
    if <source> option <dhcp>, can not option other options and parameters
    --ipaddr [<x.x.x.x>] set or get IP address
    --netmask [<x.x.x.x>] set or get IP netmask
    --gateway [<x.x.x.x>] set or get IP gateway
    --macaddr get MAC address, this only support --get
  interface:
  interface not specify is getting all network information, only support --get
  eth0 get or set eth0 network information
  eth1 get or set eth1 network information
  bond0 get or set bond0 network information
/smashclp>

```

Figure 9-44

9.11.2.2 Get Sensor Information

Via sensor command, get the information list of all sensors:

```

/smashclp> sensor --help
sensor commands:
  sensor <option1> [<option2> [<parameter2>]] [<option3> [<parameter3>]...] [parameter]
  option1:
    --help      show help information
    ?          show help information
    --list      get all sensor information
    for example : sensor --list [parameter]
/smashclp>
/smashclp> sensor --list
sensor name | num | value | unit | status | lnr | lc | lnc | unc | uc | unr
CPU0_Temp  | 19h | na | degrees C | na | na | na | na | 102.000 | 112.000 | na
CPU1_Temp  | 1Ah | na | degrees C | na | na | na | na | 102.000 | 112.000 | na
PCH_Temp   | 1Dh | na | degrees C | na | na | na | na | 100.000 | 110.000 | na
DIMMG0_Temp | 1Eh | na | degrees C | na | na | na | na | 95.000 | 105.000 | na
DIMMG1_Temp | 1Fh | na | degrees C | na | na | na | na | 95.000 | 105.000 | na
System_Temp | 01h | na | degrees C | na | na | na | na | na | na | na
Inlet_Temp  | 02h | na | degrees C | na | na | na | na | 40.000 | 50.000 | na
Outlet_Temp | 06h | na | degrees C | na | na | na | na | na | na | na
SYS_VCGT0  | 40h | na | Volts | na | 0.690 | 0.770 | 0.850 | 1.170 | 1.250 | 1.330
SYS_12V   | 43h | na | Volts | na | 9.024 | 9.776 | 10.528 | 13.536 | 14.288 | 15.040
SYS_3.3V  | 44h | na | Volts | na | 2.660 | 2.880 | 2.940 | 3.657 | 3.797 | 3.938
SYS_5V    | 47h | na | Volts | na | 3.888 | 4.176 | 4.464 | 5.544 | 5.832 | 6.120
PCH_P1V05 | 41h | na | Volts | na | 0.770 | 0.850 | 0.930 | 1.170 | 1.250 | 1.330
PCH_P1V5  | 42h | na | Volts | na | 1.180 | 1.260 | 1.340 | 1.670 | 1.750 | 1.830
CPU0_VCORE | 45h | na | Volts | na | 1.040 | 1.120 | 1.200 | 2.300 | 2.380 | 2.460
CPU1_VCORE | 46h | na | Volts | na | 1.040 | 1.120 | 1.200 | 2.300 | 2.380 | 2.460

```

Figure 9-45

9.11.2.3 Get and Set FRU Information

Via FRU command, get the FRU configuration information:

```

/smashclp> fru --help
fru commands:
fru <option1> [<option2> [<parameter>]]
option1:
--help      show help information
?           show help information
--get       get fru information
for example : fru --get <option2>
--set       set fru information
for example : fru --set <option2> <parameter>
option2:
CT          set or get fru Chassis Type
CPN         set or get fru Chassis Part Number
CS          set or get fru Chassis Serial
CE          set or get fru Chassis Extra
BD          get fru Board Mfg Date
BM          set or get fru Board Mfg
BP          set or get fru Board Product
BS          set or get fru Board Serial
BN          set or get fru Board Part Number
PM          set or get fru Product Manufacturer
PN          set or get fru Product Name
PPN         set or get fru Product Part Number
PV          set or get fru Product Version
PS          set or get fru Product Serial
PAT         set or get fru Product Asset Tag
all         get all of fru information
parameter:
the value of the fru modify, the string of value not more than 50 and the overall of fru not more than 255
If modify Chassis Type,the values are numeric, and less than 30
/smashclp>

```

Figure 9-46

9.11.2.4 Get and Control Chassis Status

Via chassis command, get and control the system power status:

```

/smashclp> chassis --help
chassis commands:
chassis <option1> [<option2> <parameter>]
option1:
--help      show help information
?           show help information
--get       get chassis information
for example : chassis --get <option2> <parameter>
--set       set chassis information
for example : chassis --set <option2> <parameter>
option2:
power       set or get host status
identify    set or get UID status
parameter:
status      get host or UID status
on          set host status power on
off         set host or UID status power off
force       set UID status all the light
Set UID light on server seconds, Please put seconds in the followed identify
for example : chassis --set identify 15. Light on 15 Seconds
The Seconds must be greater than 0 and less than or equal to 240
/smashclp>

```

Figure 9-47

9.11.2.5 Get User List and Add/Delete User

Via user command, get the user list, add or delete users.

```

/smashclp> user --help
user commands:
user <option> <value> [<option> <value> ...]
option:
  -help      show help information
  ?          show help information
  --list     show all the user of the information
  --id       The user identify
  --name     Add or modify user name
             for example : user --id <user id> --name <user name>
  --passwd   Modify user password
             for example : user --id <user id> --passwd <user password>
  --priv     Modify user privilege
             for example : user --id <user id> --priv <user priv>
  --del      Delete user
             for example : user --del <user id>
  --complexity Enable/Disable password complexity check or Get complexity
             for example : user --complexity <enable/disable/get>
<user id>:   The user id more than 1, less than 16.
<user name>: The user name cannot be longer than 16 bytes.
<user password>: The user password cannot be longer than 16 bytes.
<user priv>: The user priv is 2(USER), 3(OPERATOR), 4(ADMINISTRATOR) or 15(NO ACCESS).

/smashclp>
/smashclp> user --list
ID Name Channel Priv Limit
1 root ADMINISTRATOR
2 admin ADMINISTRATOR
3 NO ACCESS

```

Figure 9-48

9.11.2.6 Get BMC Version and Reset BMC

Via mc command, get BMC version information and reset BMC:

```

/smashclp> mc --help
mc commands:
mc <option1> [<option2>] <parameter>
option1:
  -help      show help information
  ?          show help information
  --get      get mc information
             for example : mc --get <parameter>
  --set      set mc information
             for example : mc --set <option2> <parameter>
option2:
  bmc        set bmc action, this only support --set
  kvm        set kvm action, this only support --set
  webgo      set webgo action, this only support --set
parameter:
  version    get bmc version, this only support --get command
  reset      set bmc , kvm or webgo reset action, this only support --set command

/smashclp>
/smashclp> mc --get version
Device ID      : 32
Device Revision : 1
Firmware Revision : 4.2.0
IPMI Version   : 2.0
/smashclp>

```

Figure 9-49

9.11.2.7 Set Fan Mode and Get Fan Speed

Via fan command, set the fan mode, and get the fan speed:

```

/smashclp> fan --help
fan commands:
  fan <option1> [<option2> <parameter1> [<parameter2>]]
option1:
  --help      show help information
  ?          show help information
  --get      get fan information
for example : fan --get <option2>
  --set      set fan information
for example : fan --set <option2> <parameter1> [<parameter2>]
option2:
  fanmode    set or get fanmode
for example : fan --set fanmode 0|1
  0 : auto mode
  1 : manual mode
  fanlevel   set or get fan level
for example : fan --set fanlevel <parameter1> <parameter2>
  parameter1: the fan id
  parameter2: the fan of the present

/smashclp>
/smashclp> fan --get fanlevel
ID Status SpeedPercent SpeedRPM
0 NA 0 0 PRM
1 NA 0 0 PRM
2 NA 0 0 PRM
3 NA 0 0 PRM
4 NA 0 0 PRM
5 NA 0 0 PRM
6 NA 0 0 PRM
7 NA 0 0 PRM
/smashclp>

```

Figure 9-50

9.11.2.8 Get and Set Power Module Information

Via psu command, get the power module information, and set power module as the main output:

```

/smashclp> psu --help
psu commands:
  psu <option1> <option2> [<parameter1> <parameter2>]
option1:
  --help      show help information
  ?          show help information
  --get      get psu information
for example : psu --get <option2>
  --set      set psu information
for example : psu --set <option2> [<parameter1> <parameter2>]
option2:
  psuinfo    show all psu information, this only support --get
  psumode    set psu information, this only support --set
  parameter1: the ID of the PSU module, not more than 4
  parameter2: the Action of the PSU module.
  0 represents active1, 1 represents active2, 2 represents standby1, 3 represents standby2, 4 represents normal.
/smashclp>

```

Figure 9-51

Get the power module information:

```

/smashclp> psu --get psuinfo
PSU Asset Info:
ID | Mfr ID      | Mfr Model      | Serail Number | FW Ver
0  | N/A        | N/A           | N/A          | N/A
1  | N/A        | N/A           | N/A          | 1.000
PSU Monitor Info:
ID | Status | Alert | Temp (C) | Pin (W) | Pout (W) | Vin (V) | Vout (V) | Iin (A) | Iout (A)
0  | N/A    | N/A   | N/A      | N/A     | N/A     | N/A     | N/A     | N/A     | N/A
1  | Activate| OK    | 24      | 56     | 40     | 231    | 12.33  | 0.26   | 3.28

```

Figure 9-52

9.11.2.9 Change Root Password

Via password command, change the root user's password:

```

/smashclp> password
New password:

```

Figure 9-53

9.11.2.10 Fault Diagnosis

Via diagnose command, execute the tools and commands integrated in BMC to view the BMC status.

```

/smashclp> diagnose --help
diagnose commands:
diagnose <option> [<parameter1>] [<parameter2>...]
option:
  --help      show help information
  ?          show help information
bmc diagnose support command:
  ls          show log file profile, only support parameter1 select log file
  cat        show log file content, only support parameter1 select log file
  last       show listing of last logged in users
  ifconfig   show and configure network info
  ethtool    show and configure phy configuration
  ps         report a snapshot of the current processes
  top        display Linux tasks
  dmesg      print or control the kernel ring buffer
  netstat    Print network connections and routing tables etc.
  gpiotool   bmc gpio test tool
  i2c-test   bmc i2c test tool
  pwmtachtool bmc fan test tool
  ipmitool   bmc ipmitool tool
parameter1:
  only support for option ls and cat command
  ncml       bmc service configuration
  log        bmc system log
  cpuinfo    bmc cpu info
  meminfo    bmc memory info
  slabinfo   bmc slab info
  versioninfo bmc version info
for example : diagnose ls ncml
for example : diagnose cat log debug.log
/smashclp>

```

Figure 9-54

9.11.2.11 Collect Fault Logs

Via dialog command, trigger the fault logs collection function. When the server fails, it can quickly collect the fault logs information stored in BMC. The collected fault logs can be downloaded through the browser or wget.

```

/smashclp> diaglog --help
diaglog commands:
diaglog <option1>
option1:
  --help      show help information
  ?          show help information
  --get       trigger one key log
for example : diaglog --get
/smashclp>

```

Figure 9-55

9.11.2.12 Serial Over LAN

Via sol command, perform the serial port redirection operation, to view the POST information of the serial ports during system startup.

```

/smashclp> sol --help
sol commands:
sol <option1>
option1:
  --help      show help information
  ?          show help information
  --start     start sol (text redirection)
for example : sol --start
/smashclp>
/smashclp>
/smashclp> sol --start

SOL (text redirection) is going to be executed.
Please remember the exit sequence: ~.

Press any key to continue.
Notice: SOL (Text Redirection) Starts Successfully.
Please Remember, Exit Sequence: ~.

```

Figure 9-56

9.12 Time Zone Table

Name of Time Zone	Time
Dateline Standard Time	(GMT-12:00) International Date Line West
Samoa Standard Time	(GMT-11:00) Midway Island, Samoa
Hawaiian Standard Time	(GMT-10:00) Hawaii
Alaskan Standard Time	(GMT-09:00) Alaska
Pacific Standard Time	(GMT-08:00) Pacific Time (US and Canada); Tijuana
Mountain Standard Time	(GMT-07:00) Mountain Time (US and Canada)
Mexico Standard Time 2	(GMT-07:00) Chihuahua, La Paz, Mazatlan
U.S. Mountain Standard Time	(GMT-07:00) Arizona
Central Standard Time	(GMT-06:00) Central Time (US and Canada)
Canada Central Standard Time	(GMT-06:00) Saskatchewan
Mexico Standard Time	(GMT-06:00) Guadalajara, Mexico City, Monterrey
Central America Standard Time	(GMT-06:00) Central America
Eastern Standard Time	(GMT-05:00) Eastern Time (US and Canada)
U.S. Eastern Standard Time	(GMT-05:00) Indiana (East)
S.A. Pacific Standard Time	(GMT-05:00) Bogota, Lima, Quito
Atlantic Standard Time	(GMT-04:00) Atlantic Time (Canada)
S.A. Western Standard Time	(GMT-04:00) Caracas, La Paz
Pacific S.A. Standard Time	(GMT-04:00) Santiago
Newfoundland and Labrador Standard Time	(GMT-03:30) Newfoundland and Labrador
E. South America Standard Time	(GMT-03:00) Brasilia
S.A. Eastern Standard Time	(GMT-03:00) Buenos Aires, Georgetown
Greenland Standard Time	(GMT-03:00) Greenland
Mid-Atlantic Standard Time	(GMT-02:00) Mid-Atlantic
Azores Standard Time	(GMT-01:00) Azores
Cape Verde Standard Time	(GMT-01:00) Cape Verde Islands
GMT Standard Time	(GMT) Greenwich Mean Time: Dublin, Edinburgh, Lisbon, London
Greenwich Standard Time	(GMT) Casablanca, Monrovia
Central Europe Standard Time	(GMT+01:00) Belgrade, Bratislava, Budapest, Ljubljana, Prague
Central European Standard Time	(GMT+01:00) Sarajevo, Skopje, Warsaw, Zagreb
Romance Standard Time	(GMT+01:00) Brussels, Copenhagen, Madrid, Paris
W. Europe Standard Time	(GMT+01:00) Amsterdam, Berlin, Bern, Rome, Stockholm, Vienna
W. Central Africa Standard Time	(GMT+01:00) West Central Africa
E. Europe Standard Time	(GMT+02:00) Bucharest
Egypt Standard Time	(GMT+02:00) Cairo
FLE Standard Time	(GMT+02:00) Helsinki, Kiev, Riga, Sofia, Tallinn, Vilnius
GTB Standard Time	(GMT+02:00) Athens, Istanbul, Minsk

Common Faults, Diagnosis and Troubleshooting

Israel Standard Time	(GMT+02:00) Jerusalem
South Africa Standard Time	(GMT+02:00) Harare, Pretoria
Russian Standard Time	(GMT+03:00) Moscow, St. Petersburg, Volgograd
Arab Standard Time	(GMT+03:00) Kuwait, Riyadh
E. Africa Standard Time	(GMT+03:00) Nairobi
Arabic Standard Time	(GMT+03:00) Baghdad
Iran Standard Time	(GMT+03:30) Tehran
Arabian Standard Time	(GMT+04:00) Abu Dhabi, Muscat
Caucasus Standard Time	(GMT+04:00) Baku, Tbilisi, Yerevan
Transitional Islamic State of Afghanistan Standard Time	(GMT+04:30) Kabul
Ekaterinburg Standard Time	(GMT+05:00) Ekaterinburg
West Asia Standard Time	(GMT+05:00) Islamabad, Karachi, Tashkent
India Standard Time	(GMT+05:30) Chennai, Kolkata, Mumbai, New Delhi
Nepal Standard Time	(GMT+05:45) Kathmandu
Central Asia Standard Time	(GMT+06:00) Astana, Dhaka
Sri Lanka Standard Time	(GMT+06:00) Sri Jayawardenepura
N. Central Asia Standard Time	(GMT+06:00) Almaty, Novosibirsk
Myanmar Standard Time	(GMT+06:30) Yangon Rangoon
S.E. Asia Standard Time	(GMT+07:00) Bangkok, Hanoi, Jakarta
North Asia Standard Time	(GMT+07:00) Krasnoyarsk
China Standard Time	(GMT+08:00) Beijing, Chongqing, Hong Kong SAR, Urumqi
Singapore Standard Time	(GMT+08:00) Kuala Lumpur, Singapore
Taipei Standard Time	(GMT+08:00) Taipei
W. Australia Standard Time	(GMT+08:00) Perth
North Asia East Standard Time	(GMT+08:00) Irkutsk, Ulaanbaatar
Korea Standard Time	(GMT+09:00) Seoul
Tokyo Standard Time	(GMT+09:00) Osaka, Sapporo, Tokyo
Yakutsk Standard Time	(GMT+09:00) Yakutsk
A.U.S. Central Standard Time	(GMT+09:30) Darwin
Cen. Australia Standard Time	(GMT+09:30) Adelaide
A.U.S. Eastern Standard Time	(GMT+10:00) Canberra, Melbourne, Sydney
E. Australia Standard Time	(GMT+10:00) Brisbane
Tasmania Standard Time	(GMT+10:00) Hobart
Vladivostok Standard Time	(GMT+10:00) Vladivostok
West Pacific Standard Time	(GMT+10:00) Guam, Port Moresby
Central Pacific Standard Time	(GMT+11:00) Magadan, Solomon Islands, New Caledonia
Fiji Islands Standard Time	(GMT+12:00) Fiji Islands, Kamchatka, Marshall Islands
New Zealand Standard Time	(GMT+12:00) Auckland, Wellington
Tonga Standard Time	(GMT+13:00) Nuku'alofa

10 Common Faults, Diagnosis and Troubleshooting

This chapter introduces the common server faults, as well as corresponding diagnosis and troubleshooting suggestions.

10.1 Hardware Problems

1) Power-on failure at startup

Description: After pressing the power button, the LED (power status LED, HDD status LED) on server's front control panel is off. Meanwhile, no KVM (display) output is displayed, and server chassis fans do not rotate.

Suggestions:

- a. Check the power supply situation: If the power module LED is on, it indicates normal power supply. If the power module LED is off or red, please check whether the power supply is normal, and whether the power cord is connected well.
- b. If the power supply is normal, insert the power module again, and then power on for verification.
- c. If there is a machine and a power module of the same type, you could change the power module to test whether there is a power module fault.
- d. If the instructions above do not resolve the problem, please contact Inspur customer service.

2) No display after power on

Description: After pressing the power button, the power LED on server's front control panel is on, the chassis fans rotate normally, but there's no output on the display.

Suggestions:

- a. Firstly check whether the monitor is powered up normally.
- b. If the monitor is powered up normally, check whether it is connected normally with the server's VGA port.
- c. Test on another monitor.
- d. If there is no output on the new monitor, login to the BMC Web interface. Open BMC remote KVM to check whether there is output on the monitor. If there is normal output, it indicates the VGA port may be abnormal, please contact Inspur customer service.
- e. If above operations could not resolve the problem, please contact Inspur customer

service.

3) Status LED on front panel is abnormal

Description: The server is under normal operation, but the status LED on front panel turns red.

Suggestions:

- a. Firstly confirm which LED is abnormal according to the previous chapter about the LEDs on the front panel.
- b. If the system failure LED is abnormal, check whether the system runs normally; if the system runs normally, you can login to the BMC Web interface to view the BMC logs, to check whether there are errors reported.
- c. If the power failure LED is abnormal, check whether the power module LED is normal; if the power module LED is normal, you can login to the BMC Web interface to view the BMC logs, to check whether there are errors reported.
- d. If other LEDs are abnormal, you can login to the BMC Web interface to view the BMC logs, to check whether there are errors reported.
- e. If above operations could not resolve the problem, please contact Inspur customer service.

4) Power module LED is off or red

Description: The server is under normal operation, but a certain power module LED is off or red.

Suggestions:

- a. Firstly check whether all power cables are normal, and plug in the power cables again.
- b. If the fault still exists, insert the power module again.
- c. If shutdown is allowed, you could exchange the two power modules to judge whether it is a power module fault.
- d. If above operations could not resolve the problem, please contact Inspur customer service.

5) HDD status LED is abnormal

Description: The server is under normal operation, but the HDD status LED is off or red.

Suggestions:

- a. If it is caused by manual operations, restore the array through RAID configuration.
- b. If there is no manual operations, check whether the HDDs are identified normally. If the server is configured with an RAID card, login to the RAID management interface to check whether there is an HDD failure.
- c. If there is an HDD failure, or the above operations could not resolve the problem, please contact Inspur customer service.



Note: Hot-plugging HDD allows users to take out or replace the HDD without system shutdown and power off, which improves the system disaster recovery capability, scalability and flexibility. It only means the hot-plug HDD can be plugged in and out online without damage, and the following two items need to be noticed: ① Depending on the RAID level, hot plugging the HDD in the RAID will cause RAID degradation or failure. When installing a new HDD, different RAID cards have different policies, you may need to login to the RAID card management interface for recovery. ② Remove the HDD until the HDD motor stops completely, to prevent damage to the motor. For the operations on the RAID card management interface, please refer to Inspur technical website: www.4008600011.com.

6) Chassis fans make excessive noise

Suggestions:

- a. Firstly check whether the chassis fans operate at a high speed caused by the over-temperature chassis.
- b. If the chassis has a high temperature, check the temperature of server room, if it is excessively high, open the air conditioner to cool the room.
- c. If the server room's temperature is normal, check whether the front panel or chassis interior is jammed with dust, or the air inlet is blocked. It needs to improve the server room's environment, to avoid server over-temperature running because of too much dust.
- d. Check whether the server runs under high load.
- e. If above operations could not resolve the problem, please contact Inspur customer service.

7) There is alarm sound during startup

Suggestions:

Firstly identify the source of alarm sound:

- a. If the alarm sound comes from the power supply, check the power LED's status. If the power LED is abnormal, refer to item 3) to handle it.
- b. If the alarm sound comes from the chassis interior, open the chassis to identify the specific source.
- c. If the alarm sound comes from the RAID card, check the HDD LED status or login to the RAID management interface to check the HDD status. For the operations about the RAID management interface, please refer to Inspur technical website: www.4008600011.com.
- d. If above operations could not resolve the problem, please contact Inspur customer

service.

8) Keyboard and mouse are not available

Description: Neither keyboard nor mouse could be operated normally.

Suggestions:

- a. Make sure the keyboard or mouse has been connected correctly and firmly.
- b. Replace other parts to test whether it is a mouse or keyboard fault.
- c. Power cycle the server and retest.
- d. Reboot and enter BIOS or RAID configuration interface to test keyboard or mouse performance. When tested in a non-system situation, if the keyboard or mouse performance turns out to be normal, a system fault could be considered. If the keyboard or mouse fault still exists, a motherboard interface fault could be considered, and Inspur technical hotline can be called for support.

9) USB interface problem

Description: Unable to use devices with a USB interface.

Suggestions:

- a. Make sure the operating system on server supports USB devices.
- b. Make sure the system has been installed with correct USB device driver.
- c. Power off the server, and then power on again to test.
- d. Check whether the USB device is normal when connected to other hosts.
- e. If the USB device is normal when connected to other hosts, the server may be abnormal: please contact Inspur customer service.
- f. If the USB device turns out to be abnormal when connecting to other hosts, please replace the USB device.

10.2 Software Problems

1) System installation problems

Description: It fails to load the RAID driver or to create partitions larger than 2T during system installation, C disk utilization is too large, and other problems.

Suggestions:

- a. If it fails to load the driver during system installation, check the RAID driver's version, please visit Inspur website (<http://www.inspur.com>) to download the correct RAID driver. For some RAID drivers, it needs to load several times.

- b. If it fails to create 2T partitions, check BIOS Advance ->CSM Configuration->Boot option filter, enable the UEFI option, and select UEFI mode to boot the system. It needs to enter the CMD command line to change the HDD format to GPT, and then partitions larger than 2T can be created.
- c. If the C disk utilization is too large after system installation, open Computer Property->Advanced System Property->Advanced->Performance->Settings->Change Virtual Memory, turn down the virtual memory or allocate the virtual memory to other partitions.
- d. If above operations could not resolve the problem, please contact Inspur customer service.

2) Abnormal memory capacity

Description: The memory capacity displayed in the OS and the physical memory capacity are inconsistent.

Suggestions:

- a. Check the OS version, the supported memory capacity varies with the version of Windows OS. Enter BIOS Setup to view the memory capacity, if the memory is identified completely, the operating system may have limits to the memory capacity, e.g. Windows server 2008 x86 supports 4G memory at most.
- b. If the memory is not identified completely in BIOS Setup, confirm that the corresponding slots have been installed with memories of correct type.
- c. If above operations could not resolve the problem, please contact Inspur customer service.

3) Abnormal network

Description: The network is disconnected, or the rate is lower than the actual rate of the network port.

Suggestions:

- a. Check whether the network cable is connected well and whether the network LED flashes normally, re-insert the network cable to test again.
- b. If the problem still exists, use a computer to connect with the server directly. If the direct connection is normal, check whether the network cable or the switch port is normal.
- c. If the direct connection is abnormal, please visit Inspur website (<http://www.inspur.com>) to download the latest NIC driver.
- d. If above operations could not resolve the problem, please contact Inspur customer service.

11 Battery Replacement

If the server no longer automatically displays the correct date and time, you may need to replace the battery that provides power to the real-time clock.



WARNING: The computer contains an internal lithium manganese dioxide, a vanadium pentoxide, or an alkaline battery pack. A risk of fire and burns exists if the battery pack is not properly handled. To reduce the risk of personal injury:

- Do not attempt to recharge the battery.
- Do not expose the battery to temperatures higher than 60°C (140°F).
- Do not disassemble, crush, puncture, short external contacts, or dispose of in fire or water.
- Replace only with the spare designated for this product.

To remove the component:

1. Power down the server.
2. Extend the server from the rack.
3. Remove the access panel.
4. Remove the full-length expansion board retainer if any full-length expansion boards are installed.
5. Remove the PCI riser cage.
6. Remove the air baffle.
7. Remove the battery.

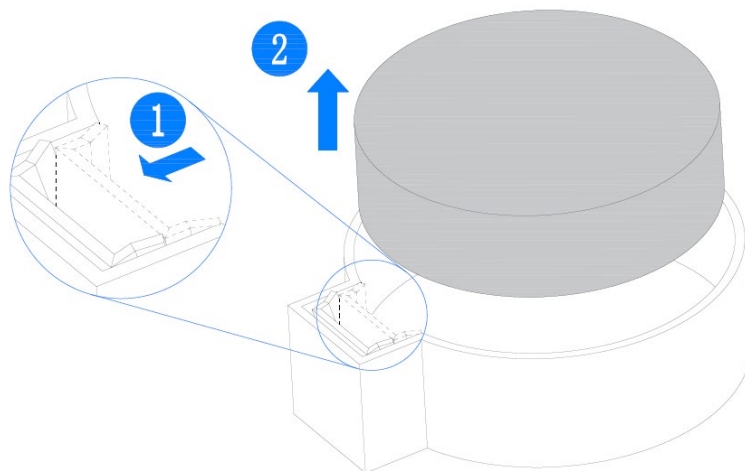

Figure 11-1

12 Regulatory Compliance Notices

12.1 Regulatory Compliance Identification Numbers

For the purpose of regulatory compliance certifications and identification, this product has been assigned a unique regulatory model number. The regulatory model number can be found on the product nameplate label, along with all required approval markings and information. When requesting compliance information for this product, always refer to this regulatory model number. The regulatory model number is not the marketing name or model number of the product.

12.2 Federal Communications Commission Notice

Part 15 of the Federal Communications Commission (FCC) Rules and Regulations has established Radio Frequency (RF) emission limits to provide an interference-free radio frequency spectrum. Many electronic devices, including computers, generate RF energy incidental to their intended function and are, therefore, covered by these rules. These rules place computers and related peripheral devices into two classes, A and B, depending upon their intended installation. Class A devices are those that may reasonably be expected to be installed in a business or commercial environment. Class B devices are those that may reasonably be expected to be installed in a residential environment (for example, personal computers). The FCC requires devices in both classes to bear a label indicating the interference potential of the device as well as additional operating instructions for the user.

12.2.1 FCC Rating Label

The FCC rating label on the device shows the classification (A or B) of the equipment. Class B devices have an FCC logo or ID on the label. Class A devices do not have an FCC logo or ID on the label. After you determine the class of the device, refer to the corresponding statement.

Class A Equipment

This equipment has been tested and found to comply with the limits for a Class A digital device, pursuant to Part 15 of the FCC Rules. These limits are designed to provide reasonable protection against harmful interference when the equipment is operated in a commercial environment. This equipment generates, uses, and can radiate radio frequency

energy and, if not installed and used in accordance with the instructions, may cause harmful interference to radio communications. Operation of this equipment in a residential area is likely to cause harmful interference, in which case the user will be required to correct the interference at personal expense.

12.3 Cables

Connections to this device must be made with shielded cables with metallic RFI/EMI connector hoods in order to maintain compliance with FCC Rules and Regulations.

12.4 European Union Regulatory Notice

Products bearing the CE marking comply with the following EU Directives:

- Low Voltage Directive 2014/35/EU
- EMC Directive 2014/30/EU

CE compliance of this product is valid if powered with the correct CE-marked AC adapter provided by INSPUR.

Compliance with these directives implies conformity to applicable harmonized European standards (European Norms) that are listed in the EU Declaration of Conformity issued by INSPUR for this product or product family and available (in English only) within the product documentation.

The compliance is indicated by one of the following conformity markings placed on the product:



Please refer to the regulatory label provided on the product.

12.5 Disposal of Waste Equipment by Users in the European Union

This symbol on the product or on its packaging indicates that this product must not be disposed of with other household waste. Instead, it is your responsibility to dispose of your waste equipment by handing it over to a designated collection point for the recycling of waste electrical and electronic equipment. The separate collection and recycling of your waste equipment at the time of disposal will help to conserve natural resources and ensure that it is recycled in a manner that protects human health and the environment. For more information about where you can drop off your waste equipment for recycling, please

contact your local city office, your household waste disposal service or the shop where you purchased the product.



12.6 Korean Notice

Class A Equipment

<p>A급 기기 (업무용 방송통신기기)</p>	<p>이 기기는 업무용(A급)으로 전자파적합등록을 한 기기이오니 판매자 또는 사용자는 이 점을 주의하시기 바라며, 가정 외의 지역에서 사용하는 것을 목적으로 합니다.</p>
-------------------------------	--

Class B Equipment

<p>B급 기기 (가정용 방송통신기기)</p>	<p>이 기기는 가정용(B급)으로 전자파적합등록을 한 기기로서 주로 가정에서 사용하는 것을 목적으로 하며, 모든 지역에서 사용할 수 있습니다.</p>
-------------------------------	---

12.7 Chinese Notice

Class A Equipment

声明

此为 A 级产品，在生活环境中，该产品可能会造成无线电干扰。在这种情况下，可能需要用户对其干扰采取可行的措施。

12.8 Battery Replacement Notice

 **CAUTION:** Risk of explosion if battery is replaced by an incorrect type. Dispose of used batteries according to the instructions.

 **ATTENTION:** Risque d'explosion si la batterie est remplacée par un type incorrect. Mettre au rebut les batteries usagées selon les instructions.



Batteries, battery packs, and accumulators should not be disposed of together with the general household waste. To forward them to recycling or proper disposal, use the public collection system or return them to Inspur, an authorized Inspur Partner, or their agents

12.9 Battery Caution

12.9.1 Battery use caution

When battery is used, avoid:

- High or low extreme temperatures during use, storage and transportation.
- Extremely low air pressure, or low air pressure at high altitude.
- Battery replacement.

Use the battery properly. Improper use of the battery such as the following may cause risks of fire, explosion or leakage of flammable liquid or gas.

- Replace battery with an incorrect type;
- Dispose of a battery into fire or a hot oven, or mechanically crushing or cutting of a battery;

Dispose the used battery according to your local regulations or the battery manufacturer's instructions.

12.9.2 Avertissement de l'utilisation de la batterie

Lorsque utiliser la batterie, évitez:

- Températures extrêmement élevées ou basses pendant l'utilisation, le stockage et le transport;
- Pression d'air extrêmement basse, ou pression d'air basse à haute altitude.
- Remplacement de la batterie.

Utilisez la batterie correctement. Mauvaise utilisation de la batterie comme celles mentionnées ici, peut entraîner des risques d'incendie, d'explosion ou de fuite liquide de gaz inflammables.

- Remplacer la batterie par un type incorrect;

- Disposer d'une batterie dans le feu ou un four chaud, écraser mécaniquement ou couper la batterie;

Disposer la batterie utilisée conformément à vos règlements locaux ou aux instructions du fabricant de la batterie.

12.9.3 Personal safety warnings

- Chemical Burn Hazard. This product contains a coin cell battery. Do not ingest battery. If the coin cell battery is swallowed, it can cause severe internal burns in just 2 hours and can lead to death.
- Keep new and used batteries away from children.
- If the battery compartment does not close securely, stop using the product and keep it away from children.
- If you think batteries might have been swallowed or placed inside any part of the body, seek immediate medical attention.

12.9.4 Avertissements de sécurité personnelle:

- Risque de brûlure chimique. Ce produit contient une batterie de cellules. N'ingérer pas la batterie. Si la batterie de cellule est avalée, elle peut causer de graves brûlures internes en seulement 2 heures et peut entraîner la mort.
- Gardez les batteries nouvelles ou utilisées à l'écart des enfants.
- Si le compartiment de la batterie ne se ferme pas en toute sécurité, cessez d'utiliser le produit et gardez-le à l'écart des enfants.
- Si vous pensez que des piles ont pu être avalées ou placées à l'intérieur d'une partie du corps, consultez immédiatement un médecin.

12.10 Restricted Access Area

Equipment is intended for installation in Restricted Access Area.

Les matériels sont destinés à être installés dans des EMPLACEMENTS À ACCÈS RESTREINT.

13 Electrostatic Discharge

13.1 Preventing Electrostatic Discharge

To prevent damaging the system, be aware of the precautions you need to follow when setting up the system or handling parts. A discharge of static electricity from a finger or other conductor may damage system boards or other static-sensitive devices. This type of damage may reduce the life expectancy of the device.

To prevent electrostatic damage:

- Avoid hand contact by transporting and storing products in static-safe containers.
- Keep electrostatic-sensitive parts in their containers until they arrive at static-free workstations.
- Place parts on a grounded surface before removing them from their containers.
- Avoid touching pins, leads, or circuitry.
- Always be properly grounded when touching a static-sensitive component or assembly.

13.2 Grounding Methods to Prevent Electrostatic Discharge

Several methods are used for grounding. Use one or more of the following methods when handling or installing electrostatic-sensitive parts:

- Use a wrist strap connected by a ground cord to a grounded workstation or computer chassis. Wrist straps are flexible straps with a minimum of 1 megohm ± 10 percent resistance in the ground cords. To provide proper ground, wear the strap snug against the skin.
- Use heel straps, toe straps, or boot straps at standing workstations. Wear the straps on both feet when standing on conductive floors or dissipating floor mats.
- Use conductive field service tools.
- Use a portable field service kit with a folding static-dissipating work mat.

If you do not have any of the suggested equipment for proper grounding, have an authorized reseller install the part.

For more information on static electricity or assistance with product installation, contact Inspur Customer Service.

14 Warranty

14.1 Introduction

Inspur warrants that all Inspur-branded hardware products shall provide a period of three (3) year warranty. This document describes Warranty Service, including a detailed description of service-level.

The warranty terms and conditions may vary by country, and some services and/or parts may not be available in all countries. For more information about warranty services in your country, contact Inspur technical support or Inspur local office.

14.2 Warranty Service

14.2.1 Service Overview

Table 14-1

Type	Duration
Remote Services	3 years
RMA Services	3 years

14.2.2 Warranty Service Terms & Conditions

i. Remote Services

Inspur provides 24x7 remote service through Hotline, E-mail and Website. Through Hotline and E-mail Services, Inspur engineer helps customers determine the cause of the malfunction and provide solution. Website service provides a number of resources to help customers resolve problems, and learn about our products, such as product manuals, drivers and Firmware.

Below is how to obtain our remote service:

Table 14-2

Type	Description	Response time
Hotline	1-844-860-0011(English) 1-646-517-4966(English) 86-800-860-0011(Chinese)	Within 2hrs
E-mail	serversupport@inspur.com	Within 2hrs
Website	http://en.inspur.com/	

ii. RMA Services

Customers could return defective parts to the designated Inspur site after submitting

aservice request. Inspur may, at its discretion, repair or replace the defective parts. Repair or replacement parts may be new, used, or equivalent to new in performance and reliability. Replaced or repaired parts are warranted to be free of defects in material or workmanship for ninety (90) calendar days or, for the remainder of the warranty period of the product, whichever is longer.

14.3 Warranty Exclusions

Inspur does not guarantee that there will be no interruptions or mistakes during the use of the products. Inspur will not undertake any responsibility for the losses arising from any operation not conducted according to Inspur Hardware Products.

The Warranty Service Terms & Conditions do not apply to consumable parts, as well as any products the serial number of which falls off, is damaged or obscure for the following reasons:

- Accident, misuse, abuse, defiling, improper maintenance or calibration or other external causes
- Operating beyond the parameters as stipulated in the user documentation
- Use of the software, interface, parts or supplies not provided by Inspur
- Improper preparation place or maintenance
- Virus infection
- Loss or damage in transit
- Alterations or repairs have been made by unauthorized persons, or service organizations

Inspur does not undertake any responsibility for the damages or losses of any application, data or removable storage medium. Except for the software installed by Inspur in its production of this product, Inspur is not responsible for the restoration or reinstallation of any programs or data.

15 Appendix

15.1 Drive Neodymium Content Reference

Seagate drive neodymium content reference range:

Table 15-1

Product Series Name	Neodymium Content Range		
	< 5g	5g - 25g	> 25g
Cimarron (2T/4T)	√		
Cimarron (6T/8T)		√	
Evans		√	
Kestrel	√		
MakaraBP		√	
MakaraPLUS		√	
Mobula		√	
MobulaBP		√	
Skybolt	√		
Tatsu		√	

WD drive neodymium content reference range:

Table 15-2

Product Series Name	Neodymium Content Range		
	< 5g	5g - 25g	> 25g
Rainier	√		
Libra He10		√	
Leo A		√	
Vela-A		√	
Vela-AX		√	
Vela-AP		√	
Hs14		√	
Leo-B		√	

Toshiba drive neodymium content reference range:

Table 15-3

Product Series Name	Neodymium Content Range		
	< 5g	5g - 25g	> 25g
AL14SE-Lite	√		
AL15SE	√		
AL14SX	√		
MG04 Tomcat-R SAS		√	
MG04 Tomcat-R SATA		√	
MG04 Tomcat SATA		√	
MG06 SAS		√	
MG06 SATA		√	
MG07 SAS		√	
MG07 SATA		√	